

# PRODUCT SUBMITTAL / SUBSTITUTION REQUEST

TO:

PROJECT:

SPECIFIED ITEM:

Section

Page

Paragraph

Description

## PRODUCT SUBMITTAL / SUBSTITUTION REQUESTED:

The attached submittal package includes the product description, specifications, drawings, and performance data for use in the evaluation of the request.

## SUBMITTED BY:

Name:

Signature:

Company:

Address:

Date:

Telephone:

Fax:

## FOR USE BY THE ARCHITECT AND/OR ENGINEER

**Approved**       **Approved as Noted**       **Not Approved**

(If not approved, please briefly explain why the product was not accepted.)

By:

Date:

Remarks:

# Wedge-Bolt+ Screw Anchor

## PRODUCT DESCRIPTION

The Wedge-Bolt+ anchor is a one piece, heavy duty screw anchor with a finished hex head. It is simple to install, easy to identify and fully removable. The Wedge-Bolt+ has features and benefits that make it well suited for many applications. The steel threads along the anchor body tap into the hole during installation to provide keyed engagement. Suitable base materials include normal-weight concrete, structural sand-lightweight concrete, concrete over steel deck, concrete masonry and solid clay brick. The anchor is designed for consistent and reliable performance in cracked and uncracked concrete.

## GENERAL APPLICATIONS AND USES

- Racking, shelving and material handling
- Support ledgers and temporary attachments
- Interior applications/low level corrosion environment
- Retrofits, repairs and maintenance
- Fencing and railing
- Seismic and wind loading

## FEATURES AND BENEFITS

- + Consistent performance in high and low strength concrete
- + Anchor can be installed through standard fixture holes
- + Wedge-bit size is matched to the nominal anchor diameter
- + Diameter, length and identifying marking stamped on head of each anchor
- + Fast installation with a powered impact wrench
- + One-piece, finished head design eliminates improper assembly or missing components

## APPROVALS AND LISTINGS

International Code Council, Evaluation Service (ICC-ES), ESR-2526 for concrete.  
 International Code Council, Evaluation Service (ICC-ES), ESR-1678 for concrete masonry.  
 Code compliant with the 2006 IBC, 2006 IRC, 2003 IBC, 2003 IRC and 1997 UBC  
 Tested in accordance with ACI 355.2 and ICC-ES AC193 for use in structural concrete under the design provisions of ACI 318 (Strength Design method using Appendix D)  
 Evaluated and qualified by an accredited independent testing laboratory for recognition in cracked and uncracked concrete including seismic and wind loading (Category 1 anchors)  
 Evaluated and qualified by an accredited independent testing laboratory for reliability against brittle failure, e.g. hydrogen embrittlement

## GUIDE SPECIFICATIONS

**CSI Divisions:** 03151-Concrete Anchoring, 04081 Masonry Anchoring and 05090-Metal Fastenings.  
 Screw anchors shall be Wedge-Bolt+ as supplied by Powers Fasteners, Inc., Brewster, NY. Anchors shall be installed in accordance with published instructions and the Authority Having Jurisdiction.

## MATERIAL SPECIFICATIONS

Anchor component	Specification
Anchor body and hex washer head	Case hardened low carbon steel
Plating	Zinc plating according to ASTM B 633, SC1, Type III (Fe/Zn 5) Minimum plating requirement for Mild Service Condition

SECTION CONTENTS	Page No.
General Information .....	1
Material Specifications.....	1
Installation Specifications .....	2
Installation Instructions.....	3
SD Performance Data .....	4
SD Factored Design Strength.....	6
ASD Performance Data.....	8
Masonry Performance Data.....	9
Ordering Information .....	12



**Wedge-Bolt+**

## ANCHOR MATERIALS

Zinc plated carbon steel body and hex washer head

## ANCHOR SIZE RANGE (TYP.)

1/4" diameter (uncracked concrete)  
 3/8" diameter through 3/4" diameter

## SUITABLE BASE MATERIALS

Normal-weight concrete  
 Structural sand-lightweight concrete  
 Concrete over steel deck  
 Grout-filled concrete masonry  
 Solid clay brick



**INSTALLATION SPECIFICATIONS**

**Installation Table for Wedge-Bolt+ (Design Provisions of ACI 318 Appendix D)**

Anchor Property/Setting Information	Notation	Units	Nominal Anchor Size					
			1/4"	3/8"	1/2"	5/8"	3/4"	
Nominal anchor diameter	$d_o$	in. (mm)	0.250 (6.4)	0.375 (9.5)	0.500 (12.7)	0.625 (15.9)	0.750 (19.1)	
Minimum diameter of hole clearance in fixture	$d_h$	in. (mm)	5/16 (7.9)	7/16 (11.1)	9/16 (14.3)	11/16 (17.5)	13/16 (20.6)	
Nominal drill bit diameter	$d_{bit}$	in.	1/4 Wedge-bit	3/8 Wedge-bit	1/2 Wedge-bit	5/8 Wedge-bit	3/4 Wedge-bit	
Wedge-bit tolerance range	-	in.	0.255 to 0.259	0.385 to 0.389	0.490 to 0.495	0.600 to 0.605	0.720 to 0.725	
Minimum nominal embedment depth	$h_{nom}$	in. (mm)	1-3/4 (44)	2-1/8 (54)	2-1/2 (64)	3-1/2 (89)	3-1/4 (83)	4-3/8 (111)
Effective embedment	$h_{ef}$	in. (mm)	1.100 (28)	1.426 (36)	1.652 (42)	2.502 (64)	2.146 (55)	3.102 (79)
Minimum hole depth <sup>1</sup>	$h_o$	in. (mm)	2 (51)	2-1/2 (64)	3 (76)	4 (102)	4 (102)	5 (127)
Minimum concrete member thickness <sup>1</sup>	$h_{min}$	in. (mm)	4 (102)	4 (102)	5 (127)	6 (152)	6 (152)	7 (178)
Minimum overall anchor length	$l_{anch}$	in. (mm)	2-1/4 (57)	2-1/2 (64)	3 (76)	4 (102)	4 (102)	5 (127)
Minimum edge distance <sup>1</sup>	$c_{min}$	in. (mm)	2-3/4 (70)	2-1/4 (57)	3 (76)	3 (76)	4 (102)	4 (102)
Minimum edge distance, close edge condition <sup>2</sup>	$c_{min}$	in. (mm)	-	1-3/4 (44)	1-3/4 (44)	1-3/4 (44)	1-3/4 (44)	1-3/4 (44)
Minimum spacing distance <sup>1</sup>	$s_{min}$	in. (mm)	4 (102)	3 (76)	4 (102)	4 (102)	5 (127)	5 (127)
Critical edge distance <sup>1</sup>	$c_{ac}$	in. (mm)	2-3/4 (70)	3-1/4 (83)	3 (76)	4 (102)	4 (102)	5 (127)
Maximum impact wrench power (torque)	$T_{screw}$	ft.-lb. (N-m)	115 (156)	245 (332)	300 (407)	350 (475)	400 (542)	
Impact wrench socket size	-	in.	7/16	9/16	3/4	15/16	1-1/8	
Head height	-	in.	7/32	21/64	7/16	1/2	19/32	

- For installations through the soffit of steel deck into concrete, see the installation detail. Anchors in the lower flute may be installed with a maximum 1-inch offset in either direction from center of the flute. In addition, anchors shall have an axial spacing along the flute equal to the greater of  $3h_{ef}$  or 1.5 times the flute width.
- For installations in concrete (excluding the soffit of steel deck) with the listed edge distance, the anchor spacing distance must be equal to or greater than  $5h_{nom}$ .

**Wedge-Bolt+ Anchor Detail**

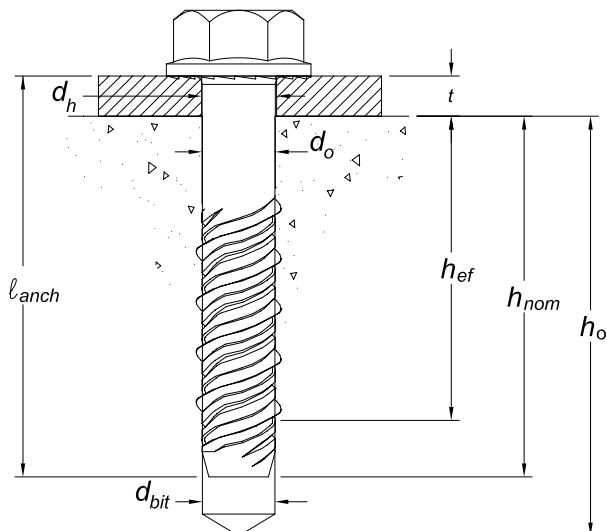

**Hex Head Marking**



**Legend**

Diameter and Length Identification Mark  
 '+' Symbol = Strength Design Compliant Anchor  
 (see ordering information)

**Matched Tolerance System**

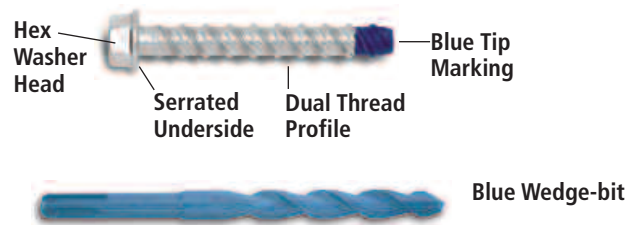

Designed and tested as a system for consistency and reliability

**INSTALLATION INSTRUCTIONS**

**Installation Instructions for Wedge-Bolt+**

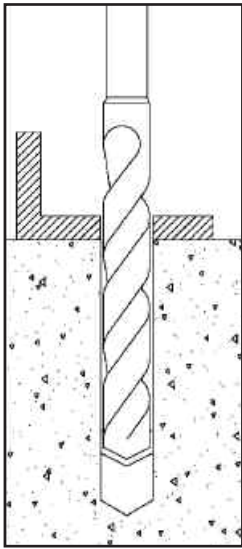

1.) Using the proper Wedge-bit size, drill a hole into the base material to the required depth. The tolerances of the carbide Wedge-bit used must meet the requirements of the published Wedge-bit range.

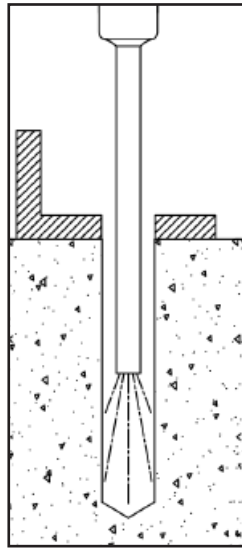

2.) Remove dust and debris from the hole.

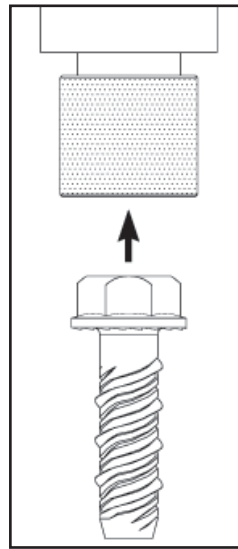

3.) Select a powered impact wrench that does not exceed the maximum torque,  $T_{screw}$ , for the selected anchor diameter. Attach an appropriate sized hex socket to the impact wrench. Mount the screw anchor head into the socket.

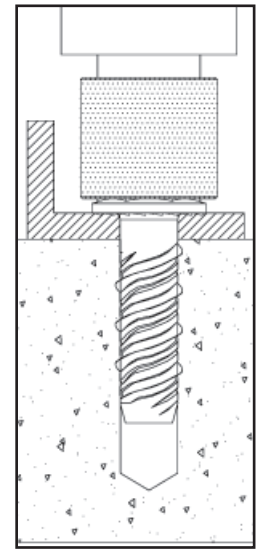

4.) Drive the anchor through the fixture and into the hole until the head of the anchor comes into contact with the fixture. The anchor should be snug after installation. Do not spin the hex socket off the anchor to disengage.

**Installation Detail for Wedge-Bolt+ Installed Through Soffit of Steel Deck into Concrete**

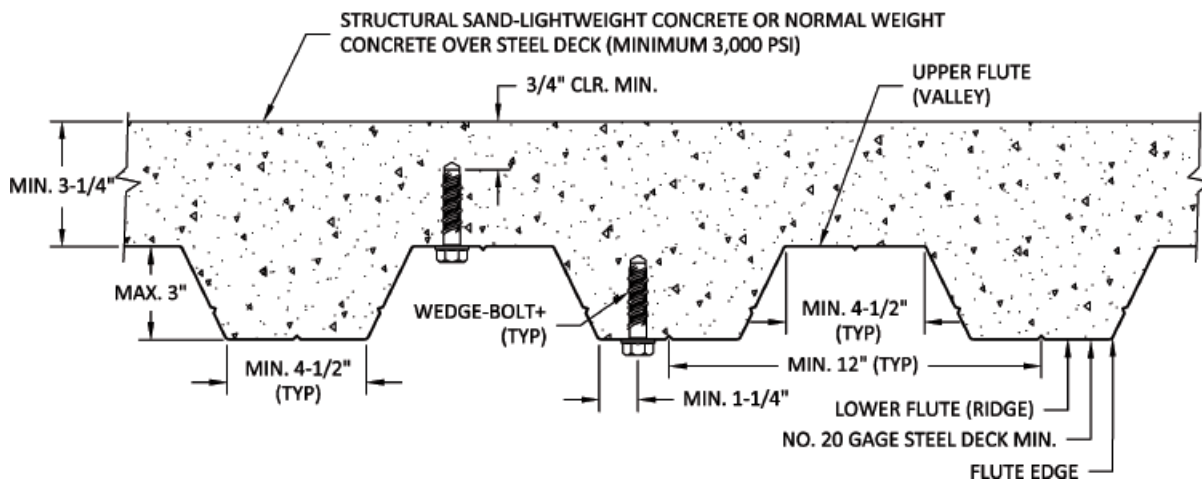

**SD PERFORMANCE DATA**

**Tension Design Information (For use with load combinations taken from ACI 318 Section 9.2)<sup>1,2,3</sup>**

Design Characteristic	Notation	Units	Nominal Anchor Size						
			1/4"	3/8"	1/2"	5/8"	3/4"		
Anchor category	1, 2 or 3	-	1	1	1	1	1	1	
Nominal embedment depth	$h_{nom}$	in.	1-3/4	2-1/8	2-1/2	3-1/2	3-1/4	4-3/8	4-1/4
<b>STEEL STRENGTH IN TENSION<sup>4</sup></b>									
Minimum specified ultimate strength	$f_{uta}$	ksi (N/mm <sup>2</sup> )	100.0 (990)	100.0 (990)	100.0 (990)	100.0 (990)	100.0 (990)	100.0 (990)	100.0 (990)
Effective tensile stress area	$A_{se}$	in <sup>2</sup> (mm <sup>2</sup> )	0.044 (1.10)	0.103 (2.66)	0.168 (4.28)	0.168 (4.28)	0.249 (6.41)	0.371 (9.53)	0.371 (9.53)
Steel strength in tension	$N_{sa}$	lb (kN)	4,400 (19.6)	10,300 (45.8)	16,800 (74.7)	16,800 (74.7)	24,900 (110.7)	37,100 (164.9)	37,100 (164.9)
Reduction factor for steel strength <sup>3</sup>	$\phi$	-	0.65						
<b>CONCRETE BREAKOUT STRENGTH IN TENSION<sup>8</sup></b>									
Effective embedment	$h_{ef}$	in. (mm)	1.100 (28)	1.426 (36)	1.652 (42)	2.502 (64)	2.146 (54)	3.102 (79)	2.909 (74)
Effectiveness factor for uncracked concrete	$k_{uncr}$	-	24	24	24	24	24	24	24
Effectiveness factor for cracked concrete	$k_{cr}$	-	Not Applicable	17	17	17	17	17	17
Modification factor for cracked and uncracked concrete <sup>5</sup>	$\psi_{c,N}$	-	1.0 See note 5	1.0 See note 5	1.0 See note 5	1.0 See note 5	1.0 See note 5	1.0 See note 5	1.0 See note 5
Critical edge distance	$c_{ac}$	in. (mm)	2-3/4 (70)	3-1/4 (83)	3 (76)	4 (102)	4 (102)	5 (127)	6 (152)
Reduction factor for concrete breakout strength <sup>3</sup>	$\phi$	-	0.65 (Condition B)						
<b>PULLOUT STRENGTH IN TENSION (NON-SEISMIC APPLICATIONS)<sup>8</sup></b>									
Characteristic pullout strength, uncracked concrete (2,500 psi) <sup>6</sup>	$N_{p,uncr}$	lb (kN)	See note 7	See note 7	See note 7	See note 7	See note 7	See note 7	See note 7
Characteristic pullout strength, cracked concrete (2,500 psi) <sup>6</sup>	$N_{p,cr}$	lb (kN)	No Data	See note 7	See note 7	2,965 (13.2)	3,085 (13.7)	4,290 (19.1)	See note 7
Reduction factor for pullout strength <sup>3</sup>	$\phi$	-	0.65 (Condition B)						
<b>PULLOUT STRENGTH IN TENSION FOR SEISMIC APPLICATIONS<sup>8</sup></b>									
Characteristic pullout strength, seismic <sup>6</sup> , (2,500 psi) <sup>9</sup>	$N_{eq}$	lb (kN)	No Data	1,085 (4.8)	1,350 (6.0)	2,520 (11.2)	3,085 (13.7)	4,290 (19.1)	4,270 (19.0)
Reduction factor for pullout strength <sup>3</sup>	$\phi$	-	0.65 (Condition B)						
<b>PULLOUT STRENGTH IN TENSION FOR STRUCTURAL SAND-LIGHTWEIGHT AND NORMAL-WEIGHT CONCRETE OVER STEEL DECK</b>									
Characteristic pullout strength, uncracked concrete over steel deck <sup>10</sup>	$N_{p,deck,uncr}$	lb (kN)	No Data	2,010 (8.9)	2,480 (11.0)	2,215 (9.8)	No Data	No Data	No Data
Characteristic pullout strength, cracked concrete over steel deck <sup>10</sup>	$N_{p,deck,cr}$	lb (kN)	No Data	1,425 (6.3)	1,755 (7.8)	1,570 (7.0)	No Data	No Data	No Data
Reduction factor for pullout strength <sup>3</sup>	$\phi$	-	0.65 (Condition B)						

- The data in this table is intended to be used with the design provisions of ACI 318 Appendix D; for anchors resisting seismic load combinations the additional requirements of ACI 318 D.3.3 shall apply.
- Installation must comply with published instructions and details.
- All values of  $\phi$  were determined from the load combinations of ACI 318 Section 9.2. If the load combinations of Appendix C are used, the appropriate value of  $\phi$  must be determined in accordance with ACI 318 D.4.5. For reinforcement that meets ACI 318 Appendix D requirements for Condition A, see ACI 318 D.4.4 for the appropriate  $\phi$  factor.
- The Wedge-Bolt+ is considered a brittle steel element as defined by ACI 318 D.1.
- For all design cases use  $\psi_{c,N} = 1.0$ . Select appropriate effectiveness factor for cracked concrete ( $k_{cr}$ ) or uncracked concrete ( $k_{uncr}$ ).
- For all design cases use  $\psi_{c,P} = 1.0$ . For concrete compressive strength greater than 2,500 psi,  $N_{pn} = (\text{pullout strength value from table}) * (\text{specified concrete compressive strength} / 2500)^{0.5}$ .
- Pullout strength does not control design of indicated anchors. Do not calculate pullout strength for indicated anchor size and embedment.
- Reported values for characteristic pullout strength in tension for seismic applications are based on test results per ACI 355.2, Section 9.5.
- Anchors are permitted to be used in structural sand-lightweight concrete provided that  $N_b$  and  $N_{pn}$  are multiplied by a factor of 0.60 (not required for steel deck).
- Values for  $N_{p,deck}$  are for structural sand-lightweight concrete ( $f'_{c,min} = 3,000$  psi) and additional lightweight concrete reduction factors need not be applied. In addition, evaluation for the concrete breakout capacity in accordance with ACI 318 D.5.2 is not required for anchors installed in the flute (soffit).

## SD PERFORMANCE DATA

Shear Design Information (For use with load combinations taken from ACI 318 Section 9.2)<sup>1,2,3</sup>

Design Characteristic	Notation	Units	Nominal Anchor Size						
			1/4"	3/8"	1/2"	5/8"	3/4"		
Anchor category	1, 2 or 3	-	1	1	1	1	1		
Nominal embedment depth	$h_{nom}$	in.	1-3/4	2-1/8	2-1/2	3-1/2	3-1/4	4-3/8	4-1/4
<b>STEEL STRENGTH IN SHEAR<sup>4,10</sup></b>									
Steel strength in shear <sup>5</sup>	$V_{sa}$	lb (kN)	2,475 (11.0)	4,825 (21.5)	7,980 (35.5)	11,990 (53.3)	19,350 (86.1)		
Reduction factor for steel strength <sup>3</sup>	$\phi$	-	0.60						
<b>CONCRETE BREAKOUT STRENGTH IN SHEAR<sup>6,10</sup></b>									
Load bearing length of anchor ( $h_{ef}$ or $8d_o$ , whichever is less)	$\ell_e$	in. (mm)	1.100 (28)	1.426 (36)	1.652 (42)	2.502 (64)	2.146 (54)	3.102 (79)	2.909 (74)
Nominal anchor diameter	$d_o$	in. (mm)	0.250 (6.4)	0.375 (9.5)	0.500 (12.7)	0.625 (15.9)	0.750 (19.1)		
Reduction factor for concrete breakout strength <sup>3</sup>	$\phi$	-	0.70 (Condition B)						
<b>CONCRETE PRYOUT STRENGTH IN SHEAR<sup>6</sup></b>									
Coefficient for prout strength (1.0 for $h_{ef} < 2.5$ in., 2.0 for $h_{ef} \geq 2.5$ in.)	$k_{cp}$	-	1.0	1.0	1.0	2.0	1.0	2.0	2.0
Effective embedment	$h_{ef}$	in. (mm)	1.100 (28)	1.426 (36)	1.652 (42)	2.502 (64)	2.146 (54)	3.102 (79)	2.909 (74)
Reduction factor for prout strength <sup>3</sup>	$\phi$	-	0.70 (Condition B)						
<b>STEEL STRENGTH IN SHEAR FOR SEISMIC APPLICATIONS<sup>10</sup></b>									
Steel strength in shear, seismic <sup>7</sup>	$V_{eq}$	lb (kN)	No Data	3,670 (16.3)	7,980 (35.5)	11,990 (53.3)	12,970 (57.7)		
Reduction factor for steel strength in shear for seismic <sup>3</sup>	$\phi$	-	0.60						
<b>STEEL STRENGTH IN SHEAR FOR STRUCTURAL SAND-LIGHTWEIGHT AND NORMAL-WEIGHT CONCRETE OVER STEEL DECK<sup>9</sup></b>									
Steel strength in shear, concrete over steel deck <sup>8</sup>	$V_{sa,deck}$	lb (kN)	No Data	1,640 (7.3)	3,090 (13.7)	No Data	No Data		
Reduction factor for steel strength in shear for steel deck <sup>3</sup>	$\phi$	-	0.60						

- The data in this table is intended to be used with the design provisions of ACI 318 Appendix D; for anchors resisting seismic load combinations the additional requirements of ACI 318 D.3.3 shall apply.
- Installation must comply with published instructions and details.
- All values of  $\phi$  were determined from the load combinations of ACI 318 Section 9.2. If the load combinations of Appendix C are used, the appropriate value of  $\phi$  must be determined in accordance with ACI 318 D.4.5. For reinforcement that meets ACI 318 Appendix D requirements for Condition A, see ACI 318 D.4.4 for the appropriate  $\phi$  factor.
- The Wedge-Bolt+ is considered a brittle steel element as defined by ACI 318 D.1.
- Reported values for steel strength in shear are based on test results per ACI 355.2, 9.4 and shall be used for design. These reported values may be lower than calculated results using equation D-20 in ACI 318-05 D.6.1.2 and D-18 in ACI 318-02, D.6.1.2.
- Anchors are permitted to be used in structural sand-lightweight concrete provided that  $V_b$  and  $V_{cp}$  are multiplied by a factor of 0.60 (not required for steel deck).
- Reported values for steel strength in shear for seismic applications are based on test results per ACI 355.2, 9.6.
- Values for  $V_{sa,deck}$  are for structural sand-lightweight concrete ( $f'_{c,min} = 3,000$  psi) and additional lightweight concrete reduction factors need not be applied. In addition, evaluation for the concrete breakout capacity in accordance with ACI 318 D.6.2 and the prout capacity in accordance with ACI 318 D.6.3 are not required for anchors installed in the flute (soffit).
- Shear loads for anchors installed through steel deck into concrete may be applied in any direction.
- For 2003 IBC code base replace  $V_{sa}$  with  $V_s$ ; and  $\ell_e$  with  $\ell$  with  $V_{eq}$  with  $V_{sa,seis}$

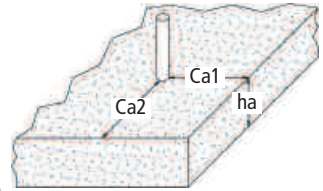

**Factored Design Strength ( $\phi N_n$  and  $\phi V_n$ ) Calculated in Accordance with ACI 318 Appendix D:**

- Tabular values are provided for illustration and are applicable for single anchors installed in normal-weight concrete with minimum slab thickness,  $h_a = h_{min}$ , and with the following conditions:
  - $C_{a1}$  is greater than or equal to the critical edge distance,  $C_{ac}$  (table values based on  $C_{a1} = C_{ac}$ ).
  - $C_{a2}$  is greater than or equal to  $1.5 C_{a1}$ .
- Calculations were performed according to ACI 318-05 Appendix D. The load level corresponding to the controlling failure mode is listed. (e.g. For *tension*: steel, concrete breakout and pullout; For *shear*: steel, concrete breakout and pryout). Furthermore, the capacities for concrete breakout strength in tension and pryout strength in shear are calculated using the effective embedment values,  $h_{ef}$ , for the selected anchors as noted in the design information tables. Please also reference the installation specifications for more information.
- Strength reduction factors ( $\phi$ ) were based on ACI 318 Section 9.2 for load combinations. Condition B is assumed.
- Tabular values are permitted for static loads only, seismic loading is not permitted with these tables.
- For designs that include combined tension and shear, the interaction of tension and shear loads must be calculated in accordance with ACI 318 Appendix D.
- Interpolation is not permitted to be used with the tabular values. For intermediate base material compressive strengths please see ACI 318 Appendix D. For other design conditions including seismic considerations please see ACI 318 Appendix D.

**Tension and Shear Design Strength for Wedge-Bolt+ in Cracked Concrete**

Nominal Anchor Size (in.)	Nominal Embed. $h_{nom}$ (in.)	Minimum Concrete Compressive Strength, $f'_c$ (psi)									
		2,500		3,000		4,000		6,000		8,000	
		$\phi N_n$ Tension (lbs.)	$\phi V_n$ Shear (lbs.)	$\phi N_n$ Tension (lbs.)	$\phi V_n$ Shear (lbs.)	$\phi N_n$ Tension (lbs.)	$\phi V_n$ Shear (lbs.)	$\phi N_n$ Tension (lbs.)	$\phi V_n$ Shear (lbs.)	$\phi N_n$ Tension (lbs.)	$\phi V_n$ Shear (lbs.)
1/4	1-3/4	-	-	-	-	-	-	-	-	-	-
3/8	2-1/8	940	940	1,030	1,030	1,190	1,190	1,460	1,460	1,685	1,685
1/2	2-1/2	1,175	1,145	1,285	1,250	1,485	1,445	1,815	1,770	2,100	2,045
	3-1/2	1,925	1,915	2,110	2,095	2,440	2,420	2,985	2,965	3,450	3,420
5/8	3-1/4	1,735	1,870	1,905	2,050	2,195	2,365	2,690	2,900	3,105	3,345
	4-3/8	2,790	2,785	3,055	3,050	3,525	3,520	4,320	4,325	4,990	4,980
3/4	4-1/4	2,740	3,180	3,005	3,485	3,465	4,025	4,245	4,925	4,905	5,690

**Tension and Shear Design Strength for Wedge-Bolt+ in Uncracked Concrete**

Nominal Anchor Size (in.)	Nominal Embed. $h_{nom}$ (in.)	Minimum Concrete Compressive Strength, $f'_c$ (psi)									
		2,500		3,000		4,000		6,000		8,000	
		$\phi N_n$ Tension (lbs.)	$\phi V_n$ Shear (lbs.)	$\phi N_n$ Tension (lbs.)	$\phi V_n$ Shear (lbs.)	$\phi N_n$ Tension (lbs.)	$\phi V_n$ Shear (lbs.)	$\phi N_n$ Tension (lbs.)	$\phi V_n$ Shear (lbs.)	$\phi N_n$ Tension (lbs.)	$\phi V_n$ Shear (lbs.)
1/4	1-3/4	900	970	985	1,060	1,140	1,225	1,395	1,485	1,610	1,485
3/8	2-1/8	1,330	1,320	1,455	1,445	1,680	1,670	2,060	2,045	2,375	2,360
1/2	2-1/2	1,655	1,600	1,815	1,755	2,095	2,025	2,565	2,480	2,965	2,865
	3-1/2	3,085	2,680	3,380	2,935	3,905	3,385	4,780	4,150	5,520	4,780
5/8	3-1/4	2,450	2,640	2,685	2,895	3,100	3,340	3,800	4,090	4,385	4,725
	4-3/8	4,260	3,900	4,670	4,270	5,390	4,930	6,600	6,040	7,625	6,975
3/4	4-1/4	3,870	4,455	4,240	4,880	4,895	5,635	5,995	6,900	6,925	7,965

**Legend**

Steel Strength Controls
  Concrete Breakout Strength Controls
  Anchor Pullout/Pryout Strength Controls

**Factored Design Strength ( $\phi N_n$  and  $\phi V_n$ ) Calculated in Accordance with ACI 318 Appendix D:**

- Tabular values are provided for illustration and are applicable for single anchors installed in normal-weight concrete with minimum slab thickness,  $h_a = h_{min}$ , and with the following conditions:
  - $c_{a1}$  is greater than or equal to the minimum edge distance, close edge condition  $c_{min}$  (table values based on  $c_{a1} = c_{min}$ ).
  - $c_{a2}$  is greater than or equal to  $1.5 c_{a1}$ .
- Calculations were performed according to ACI 318-05 Appendix D. The load level corresponding to the controlling failure mode is listed. (e.g. For *tension*: steel, concrete breakout and pullout; For *shear*: steel, concrete breakout and pryout). Furthermore, the capacities for concrete breakout strength in tension and pryout strength in shear are calculated using the effective embedment values,  $h_{ef}$ , for the selected anchors as noted in the design information tables. Please also reference the installation specifications for more information.
- Strength reduction factors ( $\phi$ ) were based on ACI 318 Section 9.2 for load combinations. Condition B is assumed.
- Tabular values are permitted for static loads only, seismic loading is not permitted with these tables.
- For designs that include combined tension and shear, the interaction of tension and shear loads must be calculated in accordance with ACI 318 Appendix D.
- Interpolation is not permitted to be used with the tabular values. For intermediate base material compressive strengths please see ACI 318 Appendix D. For other design conditions including seismic considerations please see ACI 318 Appendix D.

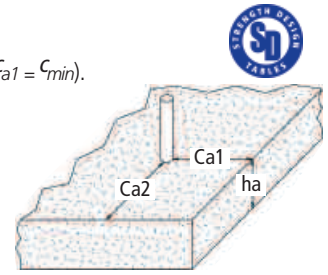

**Tension and Shear Design Strength with 1-3/4" Edge Distance for Wedge-Bolt+ in Cracked Concrete**

Nominal Anchor Size (in.)	Nominal Embed. $h_{nom}$ (in.)	Minimum Concrete Compressive Strength, $f'c$ (psi)									
		2,500		3,000		4,000		6,000		8,000	
		$\phi N_n$ Tension (lbs.)	$\phi V_n$ Shear (lbs.)	$\phi N_n$ Tension (lbs.)	$\phi V_n$ Shear (lbs.)	$\phi N_n$ Tension (lbs.)	$\phi V_n$ Shear (lbs.)	$\phi N_n$ Tension (lbs.)	$\phi V_n$ Shear (lbs.)	$\phi N_n$ Tension (lbs.)	$\phi V_n$ Shear (lbs.)
1/4	1-3/4	-	-	-	-	-	-	-	-	-	-
3/8	2-1/8	395	455	435	495	500	575	560	640	615	705
1/2	2-1/2	400	510	440	560	505	645	565	720	620	790
	3-1/2	425	555	465	605	535	700	600	785	655	855
5/8	3-1/4	415	575	450	630	520	725	585	810	640	890
	4-3/8	445	620	490	675	565	780	630	875	690	955
3/4	4-1/4	440	645	480	705	555	815	620	910	680	1,000

**Tension and Shear Design Strength with 1-3/4" Edge Distance for Wedge-Bolt+ in Uncracked Concrete**

Nominal Anchor Size (in.)	Nominal Embed. $h_{nom}$ (in.)	Minimum Concrete Compressive Strength, $f'c$ (psi)									
		2,500		3,000		4,000		6,000		8,000	
		$\phi N_n$ Tension (lbs.)	$\phi V_n$ Shear (lbs.)	$\phi N_n$ Tension (lbs.)	$\phi V_n$ Shear (lbs.)	$\phi N_n$ Tension (lbs.)	$\phi V_n$ Shear (lbs.)	$\phi N_n$ Tension (lbs.)	$\phi V_n$ Shear (lbs.)	$\phi N_n$ Tension (lbs.)	$\phi V_n$ Shear (lbs.)
1/4	1-3/4	350	535	385	585	445	675	500	755	545	545
3/8	2-1/8	370	635	405	695	465	805	520	900	570	985
1/2	2-1/2	465	715	510	780	590	900	660	1,010	725	1,105
	3-1/2	560	775	615	850	710	980	795	1,095	870	1,200
5/8	3-1/4	580	805	640	880	735	1,015	825	1,135	900	1,245
	4-3/8	585	865	640	945	740	1,095	825	1,225	905	1,340
3/4	4-1/4	450	900	495	990	570	1,140	825	1,275	695	1,395

**Legend**

Concrete Breakout Strength Controls



**ASD PERFORMANCE DATA**

**Ultimate Load Capacities for Wedge-Bolt+ Installed into Normal-Weight Concrete at 12 Diameters Spacing and Edge Distances<sup>1,2</sup>**

Anchor Diameter in. (mm)	Minimum Embedment Depth in. (mm)	Minimum Concrete Compressive Strength ( $f'_c$ )					
		2,000 psi (13.8 Mpa)		4,000 psi (27.6 Mpa)		6,000 psi (41.4 Mpa)	
		Tension lbs. (kN)	Shear lbs. (kN)	Tension lbs. (kN)	Shear lbs. (kN)	Tension lbs. (kN)	Shear lbs. (kN)
1/4 (6.4)	1 (25.4)	720 (3.2)	920 (4.0)	1,340 (6.0)	1,880 (8.3)	1,660 (7.5)	2,160 (9.6)
	1-1/2 (38.1)	1,440 (6.5)	2,000 (8.8)	2,140 (9.6)	2,080 (9.2)	2,480 (11.2)	2,260 (10.0)
	2 (50.8)	2,400 (10.8)	2,000 (8.8)	3,940 (17.7)	2,080 (9.2)	4,980 (22.4)	2,680 (11.9)
	2-1/2 (63.5)	3,520 (15.8)	2,000 (8.8)	4,660 (21.0)	2,080 (9.2)	5,260 (23.7)	2,680 (11.9)
3/8 (9.5)	1-1/2 (38.1)	1,900 (8.6)	2,760 (12.2)	2,520 (11.3)	3,440 (15.3)	3,040 (13.7)	5,600 (24.9)
	2 (50.8)	3,000 (13.5)	3,100 (13.7)	3,920 (17.6)	3,440 (15.3)	5,200 (23.4)	5,600 (24.9)
	2-1/2 (63.5)	4,100 (18.5)	3,440 (15.3)	5,320 (23.9)	3,440 (15.3)	7,340 (33.0)	5,600 (24.9)
	3 (76.2)	5,800 (26.1)	4,120 (18.3)	7,740 (34.8)	4,320 (19.2)	9,900 (44.6)	5,600 (24.9)
	3-1/2 (88.9)	7,500 (33.8)	4,820 (21.4)	10,140 (45.6)	5,200 (23.1)	12,440 (56.0)	5,600 (24.9)
1/2 (12.7)	2 (50.8)	2,860 (12.9)	4,960 (22.0)	3,940 (17.7)	5,680 (25.2)	4,780 (21.5)	7,600 (33.8)
	2-1/2 (63.5)	4,100 (18.5)	5,800 (25.8)	5,200 (23.4)	6,480 (28.8)	6,480 (28.8)	7,960 (35.4)
	3 (76.2)	5,920 (26.6)	6,200 (27.5)	7,800 (35.1)	7,240 (32.2)	9,380 (42.2)	7,960 (35.4)
	3-1/2 (88.9)	6,060 (27.3)	8,020 (35.6)	8,480 (38.2)	8,160 (36.2)	11,900 (53.6)	8,600 (38.2)
	4 (101.6)	7,560 (34.0)	8,660 (39.0)	12,620 (56.8)	9,080 (40.9)	12,620 (56.8)	9,600 (43.2)
5/8 (15.9)	2-1/2 (63.5)	3,420 (15.4)	7,200 (32.4)	4,720 (21.2)	10,240 (45.5)	6,900 (31.1)	10,180 (45.2)
	3 (76.2)	4,560 (20.5)	7,920 (35.2)	7,380 (33.2)	10,240 (45.5)	8,960 (40.3)	11,400 (50.7)
	3-1/2 (88.9)	5,720 (25.7)	8,640 (38.4)	10,040 (45.2)	10,240 (45.5)	11,040 (49.7)	11,400 (50.7)
	4 (101.6)	8,240 (37.1)	9,540 (42.4)	12,760 (57.4)	11,140 (49.5)	14,320 (64.4)	12,080 (53.7)
	4-1/2 (114.3)	10,780 (48.5)	10,460 (46.5)	15,500 (69.8)	12,040 (53.5)	17,600 (79.2)	12,760 (56.7)
	5 (127.0)	13,300 (59.9)	11,360 (50.5)	18,220 (82.0)	12,960 (57.6)	20,860 (93.9)	13,480 (59.9)
3/4 (19.1)	3 (76.2)	4,320 (19.4)	9,480 (42.1)	6,480 (29.2)	12,120 (53.9)	8,700 (39.2)	14,800 (65.8)
	3-1/2 (88.9)	5,720 (25.7)	10,460 (46.5)	9,320 (41.9)	14,820 (65.9)	11,360 (51.1)	16,400 (72.9)
	4 (101.6)	7,120 (32.0)	11,460 (50.9)	12,140 (54.6)	17,520 (77.9)	14,020 (63.1)	18,000 (80.0)
	4-1/2 (114.3)	9,240 (41.6)	13,120 (58.3)	13,580 (61.1)	18,660 (83.0)	16,720 (75.2)	19,840 (88.2)
	5 (127.0)	11,340 (51.0)	14,780 (65.7)	15,020 (67.6)	19,740 (89.8)	19,400 (87.3)	21,700 (96.5)
	5-1/2 (139.7)	13,440 (60.5)	16,640 (74.0)	16,460 (74.1)	20,840 (92.7)	22,080 (99.4)	23,560 (104.8)
	6 (152.4)	15,540 (69.9)	18,120 (80.6)	17,900 (80.6)	21,960 (97.6)	24,760 (111.4)	25,420 (113.0)

1. The values listed above are ultimate load capacities which should be reduced by a minimum safety factor of 4.0 or greater to determine the allowable working load. Consideration of safety factors of 10 or higher may be necessary depending on the application, such as life safety or overhead.

2. Linear interpolation may be used to determine ultimate loads for intermediate embedments and compressive strengths.



**MASONRY PERFORMANCE DATA**

**Allowable Load Capacities for Wedge-Bolt+ Anchors Installed into the Face of Grout Filled Concrete Masonry<sup>1,2,3,4</sup>**

Anchor Diameter (in.) (mm)	Minimum Embed. hv (in.) (mm)	Minimum Edge Distance (in.) (mm)	Minimum End Distance (in.) (mm)	Tension lbs. (kN)	Shear lbs. (kN)
1/4 (6.4)	1 (25.4)	3-3/4 (95.3)	3-3/4 (95.3)	80 (0.4)	150 (0.7)
	2 (50.8)			340 (1.5)	340 (1.5)
3/8 (9.5)	1-1/2 (38.1)	3-3/4 (95.3)	12 (304.8)	210 (0.9)	400 (1.8)
	2-1/2 (63.5)	7-7/8 (200.0)		750 (3.4)	655 (2.9)
	3-1/2 (88.9)	12 (304.8)		1,290 (5.8)	910 (4.0)
1/2 (12.7)	2 (50.8)	3-3/4 (95.3)	12 (304.8)	335 (1.5)	720 (3.2)
	3 (76.2)	7-7/8 (200.0)		930 (4.2)	900 (4.0)
	4 (101.6)	12 (304.8)		1,525 (6.9)	1,085 (4.8)
5/8 (15.9)	2-1/2 (63.5)	3-3/4 (95.3)	12 (304.8)	455 (2.0)	1,085 (4.8)
	3 1/4	7-7/8 (200.0)		885 (4.0)	1,085 (4.8)
	4 (101.6)	12 (304.8)		1,310 (5.9)	
	5 (127.0)			1,940 (8.7)	1,255 (5.6)
3/4 (19.1)	3 (76.2)	3-3/4 (95.3)	12 (304.8)	615 (2.8)	750 (3.4)
		12 (304.8)		615 (2.8)	1,320 (5.9)
	3-1/2 (88.9)	7-7/8 (200.0)		1,035 (4.7)	1,265 (5.7)
	4 (101.6)	12 (304.8)		1,455 (6.5)	1,320 (5.9)
	5 (127.0)			1,680 (7.6)	1,775 (7.9)

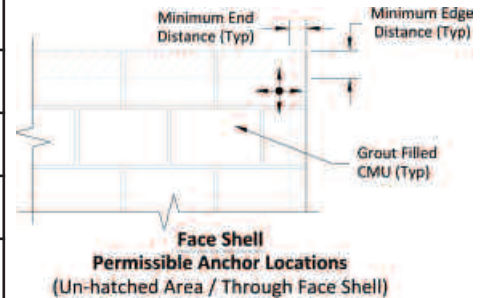

1. Tabulated load values are for anchors installed in minimum 6" wide, minimum Grade N, Type II, lightweight concrete masonry units conforming to ASTM C 90 that have reached the minimum designated ultimate compressive strength at the time of installation ( $f'_m \geq 1,500$  psi). Mortar shall be type M, S or N.
2. Allowable load capacities listed are calculated using an applied safety factor of 5.0. Consideration of safety factors of 10 or higher may be necessary depending on the application, such as life safety or overhead.
3. Linear interpolation for allowable loads for anchors at intermediate embedment depths may be used.
4. Allowable shear loads for 1/4" and 3/8" diameter anchor installations into the face shell of a masonry wall may be applied in any direction. Allowable shear loads for anchor diameters 1/2" and greater installed into the face shell may be applied in any direction provided the location is a minimum of 12" from the edge of the wall. For anchor diameters 1/2" and greater installed with an edge distance less than 12" the allowable shear loads may be applied in any direction except upward vertically.



**MASONRY PERFORMANCE DATA**

**Allowable Load Capacities for Wedge-Bolt+ Anchors Installed into the Top of Grout-Filled Concrete Masonry Wall<sup>1,2</sup>**

Nominal Anchor Diameter in. (mm)	Minimum Embed. Depth in. (mm)	Minimum Edge Distance in. (mm)	Tension lbs. (kN)	Shear lbs. (kN)
3/8 (9.5)	2-1/2 (63.5)	1-1/2 (38.1)	300 (1.6)	240 (1.1)
	1-1/2 (38.1)	2 (50.8)	-	350 (1.6)
	2-1/2 (63.5)		570 (2.5)	380 (1.7)

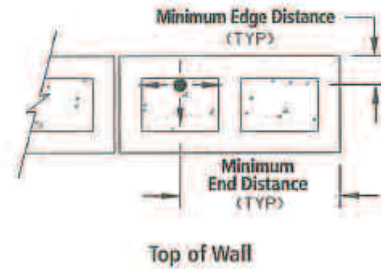

1. Tabulated load values are for Wedge-Bolt+ anchors installed in minimum 6" wide, Grade N, Type II, Lightweight concrete masonry units conforming to ASTM C 90 that have reached minimum designated compressive strength at the time of installation ( $f'_m \geq 1,500$  psi). Mortar shall be type M, S or N.
2. Allowable load capacities listed are calculated using an applied safety factor of 5.0. Consideration of safety factors of 10 or higher may be necessary depending on the application, such as life safety or overhead.

**Allowable Load Capacities for Wedge-Bolt+ Anchors Installed into the T-Joint of Grout-Filled Concrete Masonry Wall<sup>1,2,3,4</sup>**

Nominal Anchor Diameter in. (mm)	Minimum Embed. Depth in. (mm)	Minimum Edge Distance in. (mm)	Minimum End Distance in. (mm)	Tension lbs. (kN)	Shear lbs. (kN)
3/8 (9.5)	1-1/2 (38.1)	16 (406.4)	16 (406.4)	-	510 (2.3)
	3-1/2 (88.9)			830 (3.7)	
1/2 (12.7)	4 (101.6)			1,090 (4.9)	
5/8 (15.9)	4 (101.6)			840 (3.8)	1,225 (5.5)
3/4 (19.1)	2-1/2 (63.5)			-	
	4 (101.6)			890 (4.0)	

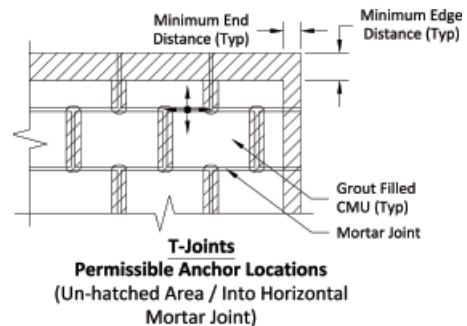

1. Tabulated load are values for Wedge-Bolt+ anchors installed in minimum 6" wide, minimum Grade N, Type II, Lightweight concrete masonry units conforming to ASTM C 90 that have reached minimum designated compressive strength at the time of installation ( $f'_m \geq 1,500$  psi). Mortar shall be type M, S or N.
2. Allowable load capacities listed are calculated using an applied safety factor of 5.0. Consideration of safety factors of 10 or higher may be necessary depending on the application, such as life safety or overhead.
3. Allowable shear loads for anchor installation into the horizontal and vertical mortar joints may be applied in any direction provided the anchor location is a minimum of 16" from the edge and end of the wall. For anchor installations with an edge distance less than 16" the allowable shear loads may be applied in any direction except upward vertically.
4. Linear interpolation for allowable loads for anchors at intermediate embedment depths may be used.

**MASONRY PERFORMANCE DATA**

**Allowable load capacities for Wedge-Bolt+ anchors installed into Multiple Wythe Solid Clay Brick Masonry<sup>1,2</sup>**

Nominal Anchor Diameter in. (mm)	Minimum Embed. Depth in. (mm)	Minimum Edge & End Distance in. (mm)	Minimum Spacing Distance in.	Tension lbs. (kN)	Shear lbs. (kN)
1/4 (6.4)	2-1/2 (63.5)	4 (101.6)	4" Any Direction	455 (2.0)	295 (1.3)
3/8 (9.5)	3-1/2 (88.9)	6 (152.4)	6" Any Direction	680 (3.1)	630 (2.8)
1/2 (12.7)	4 (101.6)	8 (203.2)	8" Any Direction	960 (4.3)	1,230 (5.5)
5/8 (15.9)	4 (101.6)	10 (254.0)	12" Any Direction	1,225 (5.5)	1,710 (7.6)
3/4 (19.1)	4 (101.6)	12 (304.8)	16" Any Direction	1,315 (5.9)	1,950 (8.7)

1. Allowable load capacities listed are calculated using an applied safety factor of 5.0. Consideration of safety factors of 10 or higher may be necessary depending on the application, such as life safety or overhead.

2. Tabulated values are for anchors installed in minimum Grade SW multiple wythe, solid clay brick masonry conforming to ASTM C 62. Mortar shall be type M, S or N.

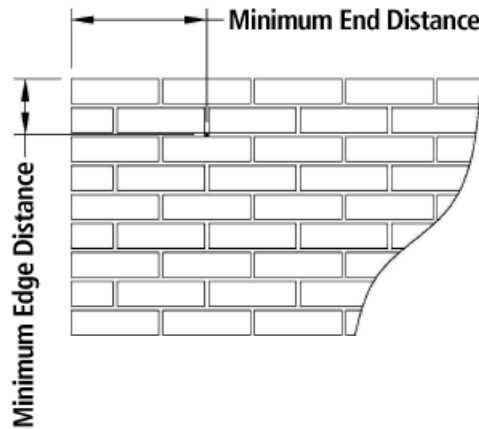

**ORDERING INFORMATION**

**Wedge-Bolt+ Screw Anchor  
(Carbon Steel with Blue Tip)**



Cat. No.	Anchor Size	Box Qty.	Carton Qty.	Wt./100 (lbs)
7204SD	1/4" x 1-1/4"	100	600	3
7206SD	1/4" x 1-3/4"	100	600	4
7208SD	1/4" x 2-1/4"	100	600	4
7210SD	1/4" x 3"	100	500	5
7220SD	3/8" x 1-3/4"	50	300	9
7222SD	3/8" x 2-1/2"	50	300	10
7224SD	3/8" x 3"	50	250	12
7226SD	3/8" x 4"	50	250	15
7228SD	3/8" x 5"	50	250	18
7230SD	3/8" x 6"	50	150	22
7240SD	1/2" x 2"	50	200	15
7242SD	1/2" x 2-1/2"	50	200	17
7244SD	1/2" x 3"	50	150	20
7246SD	1/2" x 4"	50	150	26
7248SD	1/2" x 5"	25	100	30
7250SD	1/2" x 6"	25	75	35
7268SD	1/2" x 6-1/2"	25	75	37
7252SD	1/2" x 8"	25	75	43
7260SD	5/8" x 3"	25	100	35
7262SD	5/8" x 4"	25	100	41
7264SD	5/8" x 5"	25	75	48
7266SD	5/8" x 6"	25	75	54
7270SD	5/8" x 8"	25	75	65
7280SD	3/4" x 3"	20	60	50
7282SD	3/4" x 4"	20	60	60
7284SD	3/4" x 5"	20	60	71
7286SD	3/4" x 6"	20	60	81
7288SD	3/4" x 8"	10	40	103
7290SD	3/4" x 10"	10	30	100

Shaded catalogue numbers denote sizes which are less than the minimum standard anchor length for Strength Design.  
The published size includes the diameter and length of the anchor measured from under the head.  
Wedge-Bolt+ is marked with a blue tip and must be installed with a matched tolerance Wedge-bit.

**Wedge-bits**



Cat. No.	Wedge-bit Description	Usable Length	Tube Qty.	Carton Qty.
01312	SDS 1/4" x 4"	2"	1	250
01314	SDS 1/4" x 6"	4"	1	100
01316	SDS 3/8" x 6"	4"	1	200
01318	SDS 3/8" x 8"	6"	1	100
01319	SDS 3/8" x 18"	16"	1	50
01332	SDS 3/8" x 12"	10"	1	50
01320	SDS 1/2" x 6"	4"	1	150
01322	SDS 1/2" x 10"	8"	1	50
01334	SDS 1/2" x 12"	10"	1	50
01335	SDS 1/2" x 18"	16"	1	50
01324	SDS 5/8" x 8"	6"	1	75
01326	SDS 5/8" x 12"	10"	1	75
01336	SDS 5/8" x 18"	16"	1	50
01328	SDS 3/4" x 8"	6"	1	100
01330	SDS 3/4" x 12"	10"	1	50
01340	Spline 1/2" x 13"	8"	1	20
01342	Spline 1/2" x 16"	11"	1	-
01344	Spline 5/8" x 13"	8"	1	20
01348	Spline 3/4" x 13"	8"	1	20
01354	SDS-Max 1/2" x 13"	8"	1	20
01356	SDS-Max 5/8" x 13"	8"	1	20
01358	SDS-Max 3/4" x 13"	8"	1	20
01370	HD Straight Shank 1/4" x 4"	2-1/2"	1	100
01372	HD Straight Shank 1/4" x 6"	4"	1	-
01380	HD Straight Shank 3/8" x 6"	4"	1	-
01384	HD Straight Shank 3/8" x 13"	11"	1	-
01390	HD Straight Shank 1/2" x 6"	4"	1	-
01394	HD Straight Shank 1/2" x 13"	11"	1	50
01396	HD Straight Shank 5/8" x 13"	11"	1	-
01397	HD Straight Shank 3/4" x 13"	11"	1	-

**Installation Accessories**



Cat. No.	Description	Box Qty.
08280	Hand pump / dust blower	1