

CODE LISTED
ICC-ES ESR-2502
CATEGORY 1
CRACKED &
UNCRACKED CONCRETE

Power-Stub™ SD2

Strength Design Anchoring System



America's
Strongest
Fastener
in America, NY

Powers is a proud member of:



Powers
FASTENERS

Power-Stud™ + SD2

Wedge Expansion Anchor

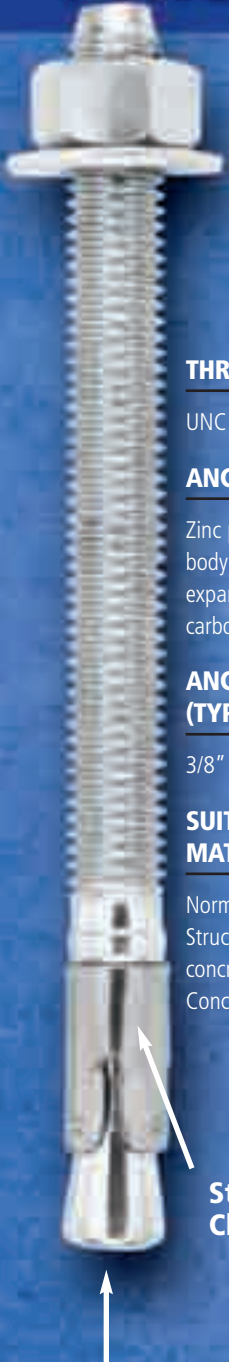

THREAD VERSION

UNC Thread

ANCHOR MATERIALS

Zinc plated carbon steel body with stainless steel expansion clip, zinc plated carbon steel nut and washer

ANCHOR SIZE RANGE (TYP.)

3/8" through 3/4" diameter

SUITABLE BASE MATERIALS

Normal-weight concrete
Structural sand-lightweight concrete
Concrete over steel deck

Stainless Steel Clip

Carbon Steel Bolt

PRODUCT DESCRIPTION

The Power-Stud+ SD2 anchor is a fully threaded, torque-controlled, wedge expansion anchor which is designed for consistent performance in cracked and uncracked concrete. Suitable base materials include normal-weight concrete, structural sand-lightweight concrete and concrete over metal deck. The anchor is manufactured with a zinc plated carbon steel body and stainless steel expansion clip for premium performance. Nut and washer are included.

GENERAL APPLICATIONS AND USES

- Structural connections, i.e., beam and column anchorage
- Safety-related attachments
- Interior applications / low level corrosion environment
- Tension zone applications, i.e., cable trays and strut, pipe supports, fire sprinklers
- Seismic and wind loading applications

FEATURES AND BENEFITS

- Consistent performance in high and low strength concrete
- Nominal drill bit size is the same as the anchor diameter
- Length ID code and identifying marking stamped on head of each anchor
- Anchor can be installed through standard fixture holes
- Anchor design allows for follow-up expansion after setting under tensile loading

APPROVALS AND LISTINGS

- International Code Council, Evaluation Service (ICC-ES), ESR-2502
- Tested in accordance with ACI 355.2 and ICC-ES AC193 for use in concrete under the design provisions of ACI 318 (Strength Design method using Appendix D)
- Evaluated and qualified by an accredited independent testing laboratory for use in cracked and uncracked concrete including seismic and wind loading (Category 1 anchors)
- Factory Mutual Approval for 3/8" and 1/2" diameters, File number 3033795
- Underwriters Laboratory (UL Listed) File No. EX1289

GUIDE SPECIFICATIONS

CSI Divisions: 03151-Concrete Anchoring and 05090-Metal Fastenings.
Expansion anchors shall be Power-Stud+ SD2 anchors as supplied by Powers Fasteners, Inc., Brewster, NY.

MATERIAL SPECIFICATIONS

Anchor component	Specification
Anchor body	Medium carbon steel
Hex nut	Carbon steel, ASTM A 563, Grade A
Washer	Carbon steel, ASTM F 844; meets dimensional requirements of ANSI B18.22.2, Type A Plain
Expansion wedge (clip)	Type 316 stainless steel
Plating (anchor body, nut and washer)	Zinc plating according to ASTM B 633, SC1, Type III (Fe/Zn 5) Minimum plating requirement for mild Service Condition

Power-Stud™ + SD2



INSTALLATION SPECIFICATIONS

Installation Table for Power-Stud+ SD2

Anchor Property/Setting Information	Notation	Units	Nominal Anchor Size							
			3/8"	1/2"	5/8"	3/4"	3/8"	1/2"	5/8"	3/4"
Anchor diameter	d_o	in. (mm)	0.375 (9.5)	0.500 (12.7)	0.625 (15.9)	0.750 (19.1)				
Minimum diameter of hole clearance in fixture	d_h	in. (mm)	7/16 (11.1)	9/16 (14.3)	11/16 (17.5)	13/16 (20.6)				
Nominal drill bit diameter	d_{bit}	in.	3/8 ANSI	1/2 ANSI	5/8 ANSI	3/4 ANSI				
Minimum nominal embedment depth	h_{nom}	in. (mm)	2-3/8 (60)	2-1/2 (64)	3-3/4 (95)	3-7/8 (98)	4-7/8 (124)	4-1/2 (114)	5-3/4 (146)	
Effective embedment	h_{ef}	in. (mm)	2 (51)	2 (51)	3-1/4 (83)	3-1/4 (83)	4-1/4 (108)	3-3/4 (95)	5 (127)	
Minimum hole depth ¹	h_o	in. (mm)	2-5/8 (67)	2-3/4 (70)	4 (102)	4-1/4 (108)	5-1/4 (133)	5 (127)	6-1/4 (159)	
Minimum concrete member thickness ¹	h_{min}	in. (mm)	4 (102)	4-1/2 (114)	5-3/4 (146)	5-3/4 (146)	6-1/2 (165)	7 (178)	10 (254)	
Minimum overall anchor length	$anch$	in. (mm)	3 (76)	3-3/4 (95)	4-1/2 (114)	4-3/4 (121)	6 (152)	6-1/4 (159)	7 (178)	
Minimum edge distance ¹	c_{min}	in. (mm)	2-1/2 (64)	4 (102)	4 (102)	4-1/4 (108)	4-1/4 (108)	5 (127)	4-1/2 (114)	
Minimum spacing distance ¹	s_{min}	in. (mm)	3-1/2 (89)	6 (152)	4 (102)	4-1/4 (108)	4-1/4 (108)	6 (152)	6 (152)	
Critical edge distance ¹	c_{ac}	in. (mm)	8 (203)	8 (203)	10 (254)	8 (203)	15-3/4 (400)	12 (305)	12 (305)	
Installation torque	T_{inst}	ft.-lb. (N-m)	20 (27)	40 (54)	60 (81)	110 (149)				
Torque wrench socket size	-	in.	9/16	3/4	15/16	1-1/8				
Nut height	-	in.	21/64	7/16	35/64	41/64				

1. For installations through the soffit of steel deck into concrete see installation detail. Anchors in the lower flute may be installed with a maximum 1 – inch offset in either direction from the center of the flute. In addition, anchors still have an axial spacing along the flute equal to the greater of $3h_{ef}$ or 1.5 times the flute width.

Power-Stud+ SD2 Anchor Detail

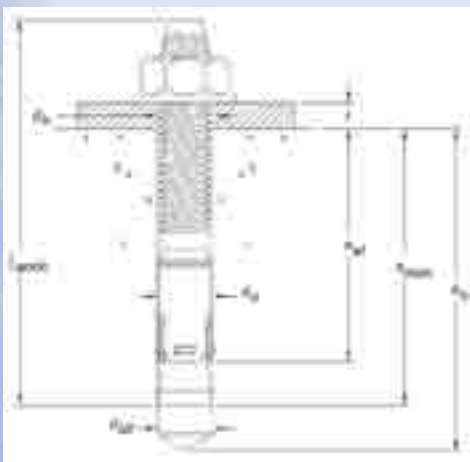

Length Identification

Mark	A	B	C	D	E	F	G	H
From	1-1/2"	2"	2-1/2"	3"	3-1/2"	4"	4-1/2"	5"
Up to but not including	2"	2-1/2"	3"	3-1/2"	4"	4-1/2"	5"	5-1/2"

Length identification mark indicates overall length of anchor.

Mark	I	J	K	L	M	N	O	P
From	5-1/2"	6"	6-1/2"	7"	7-1/2"	8"	8-1/2"	9"
Up to but not including	6"	6-1/2"	7"	7-1/2"	8"	8-1/2"	9"	9-1/2"

Head Marking Legend



Letter code = Length Identification Mark

'+' Symbol = Strength Design Compliant Anchor

Number Code = Carbon Steel Body and Stainless Steel Expansion Clip

Power-Stud™ + SD2

Wedge Expansion Anchor for use with Strength Design



INSTALLATION SPECIFICATIONS

Installation Instructions for Power-Stud+ SD2

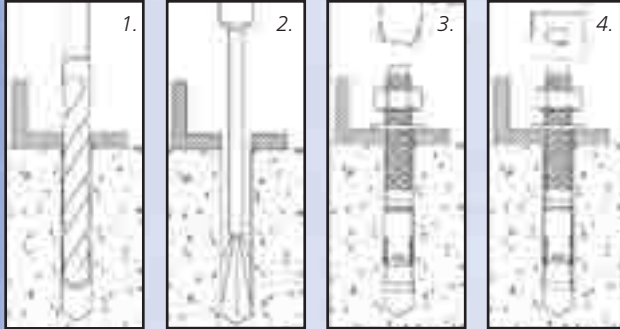

1.) Using the proper drill bit size, drill a hole into the base material to the required depth. The tolerances of the drill bit used should meet the requirements of ANSI Standard B212.15.

2.) Remove dust and debris from the hole.

3.) Position the washer on the anchor and thread on the nut. If installing through a fixture, drive the anchor through the fixture into the hole. Be sure the anchor is driven to the minimum required nominal embedment depth, h_{nom} .

4.) Tighten the anchor with a torque wrench by applying the required installation torque, T_{inst} .

Installation Detail for Power-Stud+ SD2 Installed Through Soffit of Steel Deck Into Concrete

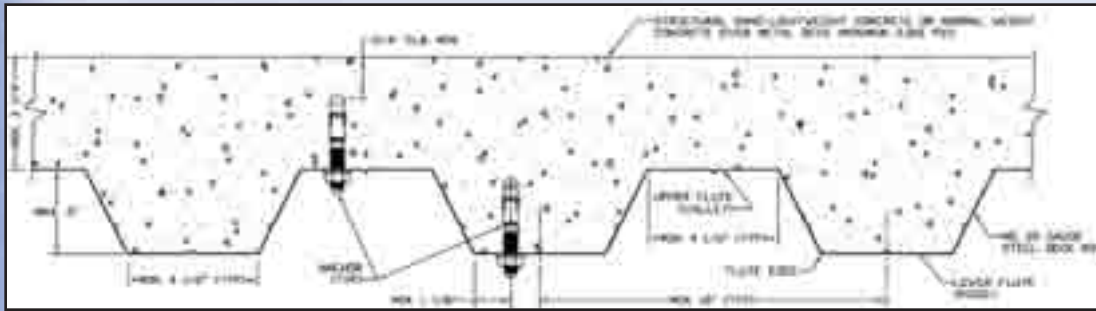

ORDERING INFORMATION

Power-Stud+ SD2 (Carbon Steel Body with Stainless Steel Clip)

Cat. No.	Anchor Size	Min. Hole Depth	Thread Length	Box Qty.	Ctn. Qty.	Wt./100 (lbs)
7413SD2	3/8" x 3"	2-5/8"	1-3/4"	50	300	10
7414SD2	3/8" x 3-1/2"	2-5/8"	2-1/4"	50	300	12
7415SD2	3/8" x 3-3/4"	2-5/8"	2-1/2"	50	300	13
7416SD2	3/8" x 5"	2-5/8"	3-3/4"	50	300	16
7422SD2	1/2" x 3-3/4"	2-3/4"	2-1/8"	50	200	23
7423SD2	1/2" x 4-1/2"	2-3/4"	2-7/8"	50	200	28
7424SD2	1/2" x 5-1/2"	2-3/4"	3-7/8"	50	150	32
7426SD2	1/2" x 7"	2-3/4"	5-3/8"	25	100	44
7427SD2	1/2" x 8-1/2"	2-3/4"	6-7/8"	25	100	46
7435SD2	5/8" x 4-3/4"	4-1/4"	2-7/8"	25	100	52
7433SD2	5/8" x 5"	4-1/4"	3-1/8"	25	100	57
7434SD2	5/8" x 6"	4-1/4"	4-1/8"	25	75	64
7436SD2	5/8" x 7"	4-1/4"	5-1/8"	25	75	72
7438SD2	5/8" x 8-1/2"	4-1/4"	6-5/8"	25	75	84
7442SD2	3/4" x 5-1/2"	5"	3-1/4"	20	60	88
7444SD2	3/4" x 6-1/4"	5"	4"	20	60	90
7446SD2	3/4" x 7"	5"	4-3/4"	20	60	95
7448SD2	3/4" x 8-1/2"	5"	6-1/4"	10	60	95

Installation Accessories

Cat. No.	Description	Wt./100 (lbs)
08465	Adjustable torque wrench with 1/2" square drive (10 to 150 ft.-lbs.)	1
08280	Hand pump / dust blower	1



The published size includes the diameter and the overall length of the anchor. All anchors are packaged with nuts and washers.

PERFORMANCE DATA

Tension Design Information (For use with load combinations taken from ACI 318 Section 9.2)^{1,2,3}

Design Characteristic	Notation	Units	Nominal Anchor Size						
			3/8"	1/2"		5/8"		3/4"	
Anchor category	1, 2 or 3	-	1	1		1		1	
Nominal embedment depth	h_{nom}	in.	2-3/8	2-1/2	3-3/4	3-7/8	4-7/8	4-1/2	5-3/4
STEEL STRENGTH IN TENSION⁴									
Minimum specified yield strength (neck)	f_y	ksi (N/mm ²)	96.0 (662)	85.0 (586)		85.0 (586)		70.0 (483)	
Minimum specified ultimate strength (neck)	f_{uta}	ksi (N/mm ²)	120.0 (827)	106.0 (731)		106.0 (731)		90.0 (620)	
Effective tensile stress area (neck)	A_{se}	in ² (mm ²)	0.0552 (35.6)	0.1007 (65.0)		0.1619 (104.5)		0.2359 (153.2)	
Steel strength in tension	N_{sa}	lb (kN)	6,625 (29.4)	10,445 (48.0)		13,080 (58.2)		21,230 (94.4)	
Reduction factor for steel strength ³	ϕ	-	0.75						
CONCRETE BREAKOUT STRENGTH IN TENSION⁸									
Effective embedment	h_{ef}	in. (mm)	2.00 (51)	2.00 (51)	3.25 (83)	3.25 (83)	4.25 (108)	3.75 (95)	5.00 (127)
Effectiveness factor for uncracked concrete	k_{uncr}	-	24	24		24		24	
Effectiveness factor for cracked concrete	k_{cr}	-	17	17		17		17	
Modification factor for cracked and uncracked concrete ⁵	$\psi_{c,N}$	-	1.0 See note 5	1.0 See note 5		1.0 See note 5		1.0 See note 5	
Critical edge distance	c_{ac}	in. (mm)	8 (203)	8 (203)	10 (254)	8 (203)	15-3/4 (400)	12 (305)	12 (305)
Reduction factor for concrete breakout strength ³	ϕ	-	Condition B = 0.65						
PULLOUT STRENGTH IN TENSION (NON-SEISMIC APPLICATIONS)⁸									
Characteristic pullout strength, uncracked concrete (2,500 psi) ⁶	$N_{p,uncr}$	lb (kN)	2,775 (12.3)	See note 7	6,615 (29.4)	See note 7	See note 7	See note 7	See note 7
Characteristic pullout strength, cracked concrete (2,500 psi) ⁶	$N_{p,cr}$	lb (kN)	2,165 (9.6)	See note 7	4,375 (19.5)	See note 7	4,980 (22.4)	See note 7	7,795 (35.1)
Reduction factor for pullout strength ³	ϕ	-	Condition B = 0.65						
PULLOUT STRENGTH IN TENSION FOR SEISMIC APPLICATIONS⁸									
Characteristic pullout strength, seismic ^{6,9}	$N_{p,seis}$	lb (kN)	2,165 (9.6)	See note 7	4,375 (19.5)	See note 7	4,980 (22.4)	See note 7	7,795 (35.1)
Reduction factor for pullout strength ³	ϕ	-	Condition B = 0.65						
PULLOUT STRENGTH IN TENSION FOR STRUCTURAL SAND-LIGHTWEIGHT AND NORMAL-WEIGHT CONCRETE OVER STEEL DECK									
Characteristic pullout strength, uncracked concrete over steel deck ¹⁰	$N_{p,deck,uncr}$	lb (kN)	1,855 (8.3)	2,065 (9.2)	3,930 (17.5)	4,665 (20.8)	7,365 (32.8)	4,900 (21.8)	4,900 (21.8)
Characteristic pullout strength, cracked concrete over steel deck ¹⁰	$N_{p,deck,cr}$	lb (kN)	1,445 (6.4)	1,465 (6.5)	2,600 (11.6)	3,305 (14.7)	3,490 (15.5)	3,470 (15.4)	3,470 (15.4)
Reduction factor for pullout strength ³	ϕ	-	Condition B = 0.65						

- The data in this table is intended to be used with the design provisions of ACI 318 Appendix D; for anchors resisting seismic load combinations the additional requirements of Section D.3.3 shall apply.
- Installation must comply with published instructions and details.
- All values of ϕ were determined from the load combinations of ACI 318 Section 9.2. If the load combinations of Appendix C are used, the appropriate value of ϕ must be determined in accordance with ACI 318 Section D.4.5. For reinforcement that meets ACI 318 Appendix D requirements for Condition A, see ACI 318 Section D.4.4 for the appropriate ϕ factor.
- The Power-Stud+ SD2 is considered a ductile steel element in tension as defined by ACI 318 Section D.1. Reported values for steel strength in tension are based on test results per ACI 355.2 and shall be used for design.
- For all design cases use $\psi_{c,N} = 1.0$. Select appropriate effectiveness factor for cracked concrete (k_{cr}) or uncracked concrete (k_{uncr}).
- For all design cases use $\psi_{c,N} = 1.0$. For concrete compressive strength greater than 2,500 psi, $N_{pn} = (\text{pullout strength value from table}) \cdot (\text{specified concrete compressive strength}/2500)^n$. For all anchors $n = 1/2$ with the exception of the 3/8" anchor size for cracked concrete where $n = 1/3$.
- Pullout strength will not control design of indicated anchors. Do not calculate pullout strength for indicated anchor size and embedment.
- Anchors are permitted to be used in structural sand-lightweight concrete provided that N_b and N_{pn} are multiplied by a factor of 0.60 (not required for steel deck).
- Reported values for characteristic pullout strength in tension for seismic applications are based on test results per ACI 355.2, Section 9.5.
- Values for $N_{p,deck}$ are for structural sand-lightweight concrete ($f'_{c,min} = 3,000$ psi) and additional lightweight concrete reduction factors need not be applied. In addition, evaluation for the concrete breakout capacity in accordance with ACI 318 Section D.5.2 is not required for anchors installed in the flute (soffit).

Power-Stud™ + SD2

PERFORMANCE DATA

Shear Design Information (For use with load combinations taken from ACI 318 Section 9.2)^{1,2}

Design Characteristic	Notation	Units	Nominal Anchor Size						
			3/8"	1/2"	5/8"	3/4"	1"	1 1/4"	1 1/2"
Anchor category	1, 2 or 3	-	1	1	1	1	1	1	1
Nominal embedment depth	h_{nom}	in.	2-3/8	2-1/2	3-3/4	3-7/8	4-7/8	4-1/2	5-3/4
STEEL STRENGTH IN SHEAR⁴									
Minimum specified yield strength (threads)	f_y	ksi (N/mm ²)	76.8 (530)	84.8 (585)	84.8 (585)	68.0 (469)	68.0 (469)	56.0 (386)	56.0 (386)
Minimum specified ultimate strength (threads)	f_{uta}	ksi (N/mm ²)	96.0 (662)	84.8 (585)	84.8 (585)	84.8 (585)	84.8 (585)	72.0 (496)	72.0 (496)
Effective tensile stress area (threads)	A_{se}	in ² (mm ²)	0.0775 (50.0)	0.1419 (65.7)	0.1419 (65.7)	0.2260 (104.9)	0.2260 (104.9)	0.3345 (215.8)	0.3345 (215.8)
Steel strength in shear ⁵	V_{sa}	lb (kN)	2,190 (9.7)	4,640 (20.6)	4,640 (20.6)	9,800 (44.1)	9,800 (44.1)	10,175 (45.3)	10,175 (45.3)
Reduction factor for steel strength ³	ϕ	-	0.60	0.60	0.60	0.65	0.65	0.65	0.65
CONCRETE BREAKOUT STRENGTH IN SHEAR⁶									
Load bearing length of anchor (h_{ef} or $8d_o$, whichever is less)	e	in. (mm)	2.00 (51)	2.00 (51)	3.25 (83)	3.25 (83)	4.25 (108)	3.75 (95)	5.00 (127)
Reduction factor for concrete breakout strength ³	ϕ	-	Condition B = 0.70						
CONCRETE PRYOUT STRENGTH IN SHEAR⁶									
Coefficient for prout strength (1.0 for $h_{ef} < 2.5$ in., 2.0 for $h_{ef} \geq 2.5$ in.)	k_{cp}	-	1.0	1.0	2.0	2.0	2.0	2.0	2.0
Effective embedment	h_{ef}	in. (mm)	2.00 (51)	2.00 (51)	3.25 (83)	3.25 (83)	4.25 (108)	3.75 (95)	5.00 (127)
Reduction factor for prout strength ³	ϕ	-	Condition B = 0.70						
STEEL STRENGTH IN SHEAR FOR SEISMIC APPLICATIONS⁶									
Steel strength in shear, seismic ⁷	$V_{sa,seis}$ (V_{eq})	lb (kN)	1,955 (8.7)	4,640 (20.6)	4,640 (20.6)	6,530 (29.0)	6,530 (29.0)	6,635 (29.5)	6,635 (29.5)
Reduction factor for steel strength in shear, seismic ³	ϕ	-	0.60	0.60	0.60	0.65	0.65	0.65	0.65
STEEL STRENGTH IN SHEAR FOR STRUCTURAL SAND-LIGHTWEIGHT AND NORMAL-WEIGHT CONCRETE OVER STEEL DECK⁹									
Steel strength in shear, concrete over steel deck ⁸	$V_{sa,deck}$	lb (kN)	2,170 (9.7)	3,815 (17.0)	5,040 (22.4)	4,015 (17.9)	6,670 (29.7)	4,325 (19.2)	4,325 (19.2)
Reduction factor for steel strength in shear for concrete over steel deck ³	ϕ	-	0.60	0.60	0.60	0.65	0.65	0.65	0.65

1. The data in this table is intended to be used with the design provisions of ACI 318 Appendix D; for anchors resisting seismic load combinations the additional requirements of Section D.3.3 shall apply.

2. Installation must comply with published instructions and details.

3. All values of ϕ were determined from the load combinations of ACI 318 Section 9.2. If the load combinations of Appendix C are used, the appropriate value of ϕ must be determined in accordance with ACI 318 Section D.4.5. For reinforcement that meets ACI 318 Appendix D requirements for Condition A, see ACI 318 Section D.4.4 for the appropriate ϕ factor.

4. The Power-Stud+ SD2 is considered a ductile steel element as defined by ACI 318 Section D.1 with the exception of the 3/8" anchor size in shear.

5. Reported values for steel strength in shear are based on test results per ACI 355.2, Section 9.4 and shall be used for design. These reported values may be lower than calculated results using equation D-20 in ACI 318-05 Section D.6.1.2 and D-18 in ACI 318-02, Section D.6.1.2.

6. Anchors are permitted to be used in structural sand-lightweight concrete provided that V_b and V_{cp} are multiplied by a factor of 0.60 (not required for steel deck).

7. Reported values for steel strength in shear for seismic applications are based on test results per ACI 355.2, Section 9.6.

8. Values for $V_{sa,deck}$ are for structural sand-lightweight concrete ($f'_c, min = 3,000$ psi) and additional lightweight concrete reduction factors need not be applied. In addition, evaluation for the concrete breakout capacity in accordance with ACI 318 Section D.6.2 and the prout capacity in accordance with Section D.6.3 are not required for anchors installed in the flute (soffit).

9. Shear loads for anchors installed through steel deck into concrete may be applied in any direction.

Factored Resistance Strength (ϕN_n and ϕV_n) Calculated in Accordance with Appendix D:

- Tabular values are provided for illustration and are applicable for single anchors installed in normal-weight concrete with minimum slab thickness, $h_a = h_{min}$, and with the following conditions:
 - c_{a1} is greater than or equal to the critical edge distance, c_{ac} (table values based on $c_{a1} = c_{ac}$).
 - c_{a2} is greater than or equal to 1.5 times c_{a1} .
- Calculations were performed according to ACI 318-05 Appendix D. The load level corresponding to the controlling failure mode is listed (e.g. For *tension*: steel, concrete breakout and pullout; For *shear*: steel, concrete breakout and pryout). Furthermore, the capacities for concrete breakout strength in tension and pryout strength in shear are calculated using the effective embedment values, h_{ef} , for the selected anchors as noted in the design information tables. Please also reference the installation specifications for more information.
- Strength reduction factors (ϕ) were based on ACI 318 Section 9.2 for load combinations. Condition B is assumed.
- Tabular values are permitted for static loads only, seismic loading is not permitted with these tables.
- For designs that include combined tension and shear, the interaction of tension and shear loads must be calculated in accordance with ACI 318 Appendix D.
- Interpolation is not permitted to be used with the tabular values. For intermediate base material compressive strengths please see ACI 318 Appendix D. For other design conditions including seismic considerations please see ACI 318 Appendix D.



Tension and Shear Factored Resistance Strength for Power-Stud+ Sd2 in Cracked Concrete

Nominal Anchor Size (in.)	Nominal Embed. (in.) h_{ef}	Minimum Concrete Compressive Strength, f'_c (psi)									
		2,500		3,000		4,000		6,000		8,000	
		ϕN_n Tension (lbs.)	ϕV_n Shear (lbs.)	ϕN_n Tension (lbs.)	ϕV_n Shear (lbs.)	ϕN_n Tension (lbs.)	ϕV_n Shear (lbs.)	ϕN_n Tension (lbs.)	ϕV_n Shear (lbs.)	ϕN_n Tension (lbs.)	ϕV_n Shear (lbs.)
3/8	2-3/8	1,405	1,315	1,495	1,315	1,645	1,315	1,885	1,315	2,075	1,315
1/2	2-1/2	1,565	1,685	1,710	1,845	1,975	2,130	2,420	2,605	2,795	3,010
	3-3/4	2,845	3,015	3,115	3,015	3,595	3,015	4,405	3,015	5,085	3,015
5/8	3-7/8	3,235	3,575	3,545	3,920	4,095	4,525	5,015	5,540	5,790	6,370
	4-7/8	3,235	4,885	3,545	5,355	4,095	6,180	5,015	6,370	5,790	6,370
3/4	4-1/2	4,010	4,730	4,395	5,185	5,075	5,985	6,215	6,615	7,175	6,615
	5-3/4	5,065	6,615	5,550	6,615	6,410	6,615	7,850	6,615	9,065	6,615

Tension and Shear Factored Resistance Strength for Power-Stud+ SD2 in Uncracked Concrete

Nominal Anchor Size (in.)	Nominal Embed. (in.) h_{ef}	Minimum Concrete Compressive Strength, f'_c (psi)									
		2,500		3,000		4,000		6,000		8,000	
		ϕN_n Tension (lbs.)	ϕV_n Shear (lbs.)	ϕN_n Tension (lbs.)	ϕV_n Shear (lbs.)	ϕN_n Tension (lbs.)	ϕV_n Shear (lbs.)	ϕN_n Tension (lbs.)	ϕV_n Shear (lbs.)	ϕN_n Tension (lbs.)	ϕV_n Shear (lbs.)
3/8	2-3/8	1,805	1,315	1,975	1,315	2,280	1,315	2,795	1,315	3,225	1,315
1/2	2-1/2	2,205	2,375	2,415	2,605	2,790	3,005	2,795	3,015	3,945	3,015
	3-3/4	4,300	3,015	4,710	3,015	5,440	3,015	6,660	3,015	7,690	3,015
5/8	3-7/8	4,570	5,005	5,005	5,485	5,780	6,335	7,080	6,370	8,175	6,370
	4-7/8	6,835	6,370	7,485	6,370	8,645	6,370	10,585	6,370	12,225	6,370
3/4	4-1/2	5,665	6,615	6,205	6,615	7,165	6,615	8,775	6,615	10,130	6,615
	5-3/4	8,720	6,615	9,555	6,615	11,030	6,615	13,510	6,615	15,600	6,615

Legend

Anchor Pullout/Pryout Strength Controls
 Concrete Breakout Strength Controls
 Steel Strength Controls

POWERS FASTENERS **BRANCH INFORMATION****USA LOCATIONS**

CITY	ADDRESS	CONTACT	PHONE	FAX
Alabama	5405 Buford Hwy Suite 410 Norcross, GA 30071-3984	Jeff Hatchett	205-520-6044	678-966-9242
Atlanta	5405 Buford Hwy Suite 410 Norcross, GA 30071-3984	Robert Brito	678-966-0000	678-966-9242
Boston	2 Powers Lane, Brewster, NY 10509	Jack Armour	800-524-3244	914-576-6483
Charlotte	349 L West Tremont Avenue, Charlotte, NC 28203	Bob Aurisy	704-375-5012	704-376-5517
Chicago	2472 Wisconsin Avenue, Downers Grove, IL 60515	Dan Gilligan	630-960-3156	630-960-3912
Dallas	10625 King Williams Drive, Dallas, TX 75220	Kyle Thuenemann	972-506-9258	972-506-9290
Denver	2475 West Second Street #35, Denver, CO 80223	Aaron Minnis	303-922-9202	303-922-9228
Detroit	21600 Wyoming Avenue, Oak Park, MI 48237	Glen Gaskill	248-543-8600	248-543-8601
Florida	9208 Palm River Road, Bldg. 3, Suite 305, Tampa, FL 33619	Mark Mamula	813-626-4500	813-626-4545
Houston	13833 North Promenade, Suite 100, Stafford, TX 77477	Chris Salisbury	281-491-0351	281-491-0367
Indianapolis	15290 Stony Creek Way, Noblesville, IN 46060	Bill Trainor	317-773-1668	317-773-1690
Kansas City / St Louis	716 East 16th Avenue, North Kansas City, MO 64116	Don James, Jr.	816-472-5038	816-472-5040
Los Angeles	2761 Dow Avenue, Tustin, CA 92780	Jack Stewart	714-731-2500	714-731-2566
Maryland	3137-B Pennsy Drive, Landover, MD 20785	Chris Van Syckle	301-773-1722	301-341-5119
Milwaukee	12020 W. Feerick Street, Milwaukee, WI 53222	Donn Raduenz	414-466-2400	414-466-3993
Minneapolis	351 Wilson Street, NE Minneapolis, MN 55413	Rick Gruye	612-331-3756	612-331-3549
Nashville/Memphis	221 Blanton Avenue, Nashville, TN 37210	Ira Liss	615-248-2667	615-248-2676
New Orleans	102 Sampson Street, Houston, TX 77003	Cal Zenor	713-228-1524	713-228-1528
New York	2 Powers Lane, Brewster, NY 10509	John Partridge	914-235-6300	914-576-6483
Philadelphia	2 Powers Lane, Brewster, NY 10509	Greg Stephenson	800-524-3244	914-576-6483
Phoenix	3602 E. Southern Ave, Suite 5 Phoenix, AZ 85040	Craig Hering	602-431-8024	602-431-8027
Pittsburgh	1360 Island Avenue, McKees Rocks, PA 15136	Bill Dugan	412-771-3010	412-771-9858
Portland	129 South Kenyon, Seattle, WA 98108	Jim Swink	360-608-6845	206-762-5817
Rochester	40 Harrison Street, Rochester, NY 14605	Mike Kolstad	585-288-2080	585-288-8732
Salt Lake City	2212 SW Temple #20, Salt Lake City, UT 84115	Don Manning	801-466-9428	801-466-3083
San Francisco	28970 Hopkins Street, Suite B+C, Hayward, CA 94545	Dan Mullan	510-293-1500	510-293-1505
Seattle	129 South Kenyon, Seattle, WA 98108	Darin Arnold	206-762-5812	206-762-5817

INTERNATIONAL LOCATIONS

COUNTRY/REGION	ADDRESS	CONTACT	PHONE	FAX
Australia	Factory 3, 205 Abbotts Road, Dandenong, South Victoria 3175	Phil Rose	+61 3 8787 5888	+61 3 8787 5899
Canada	6950 Edwards Blvd. Mississauga, Ontario L5T 2W2	Mark Russell	905-673-7295	905-673-6490
China	Metropolitan Business Centre, East Nandan Road, Lane 300, No. 9, Room 604 Xuhui District, Shanghai, China 200030	Jake Olsen	+86-21-3363-2880	+86-21-3363-2881
China	TriF International, 4E, Building 11, The City of Design, Tianmian Village, Futian, Shenzhen 518000	Tom Nie	86-755-82795378	86-755-82795379
Europe	Westrak 208, 1771 SV Wieringerwerf, Netherlands	Paul Geuvers	+31 888 769 377	+31 227 594 759
India	112, D Wing, Twin Arcade, Military Rd., Andheri, [E] Mumbai, 400059	Ajay Kulkarni	91-22-401591304	
Manitoba	1810 Dublin Avenue Man. Winnipeg, R3H 0H3	Distributor	204-633-0064	204-694-1261
New Zealand	PO Box 302 076 North Harbour Auckland	Claye Sesto	+64 9415 2425	+64 9415 2627
Quebec	721 Meloche Avenue, Dorval, Quebec H9P 2S5	Alan Hill	514-631-4216	514-631-2583
Thailand	80/89 MOO4 Petchakasem Road, Bangkai Bangkok 10160	Chalee Surakavanichakorn	+661 826 5821	

LATIN & CARIBBEAN DISTRIBUTION INQUIRIES

COUNTRY/REGION	ADDRESS	CONTACT	PHONE	FAX
Latin America	9208 Palm River Road, Ste 305, Tampa, Florida 33619	Michael Gaffigan	954-914-6665	813-626-4545

LATIN & CARIBBEAN DISTRIBUTION

COUNTRY/REGION	ADDRESS	CONTACT	PHONE	FAX
Brazil	HARD, Rua Dr. Humberto Pinheiro Viera, 150 Lote B, 1 B Distrito Industrial, Joinville, Brazil		55-47-40097209	55-47-40097217
Colombia	Electrogeno, S.A., Carrera 52 #71c-38, Bogota, Colombia		(57) 1 6600 9436	
Costa Rica	Electro Mechanics Supply, La Uruca Contiguo Banco Ntnl., De Costa Rica Condominio, Horizontal Bodega #9, San Jose, Costa Rica		(506) 2233-2595	
Dominican Republic	Calle Estancia Nueva #17 E Esquina Cul-De-Sac 9, San Geronimo, Santo Domingo	Rodfor Team	809-224-5615	809-472-8640
Ecuador	Acerco Comercial Ecuatoriano S.A., Av. La Prensa N45-14 y Telégrafo 1 – Quito Av. Juan Tanca Marengo Km. 1.7 – Guayaquil	info@acero.comercial.com info@acero.comercial.com	(593-2) 2454 333 (593-4) 2683 060	(593-2) 2454 455 (593-4) 2683 059
Guatemala	Tecnofijaciones, 6 Avenue 8-56 Zona 9, Zona 9, Guatemala	Oscar Lucas Penagos	502-233-4-3478	
Panama	Centro-Industrial, Vía Cincuentenario, No. 7910, Ciudad Panama, Panama		(507) 302-8022	
Peru	Powers Peruana SAC, Av. Santa Catalina, 555 La Victoria, Lima 13, Peru (www.powersperuana.com)	Martin Vasquez	(011) 511 265 8500	(011) 511 330 0909
Venezuela	Calle Sucre/Qta. Maudora, #1721 Entre Cec Acosta Y San Ignacio Chacao, Caracas	Distributor	58 212 264 1313	58 212 263 0219
Trinidad - Tobago	Ft. Farfan, 3-5 Ibis Avenue, Ibis Acres, San Juan	Derek Cumming	(868) 674-7896	

Note: The information and data contained within this documentation was current as of September 2010. The information is for marketing purposes only and is subject to change and updates as needed. Powers Fasteners, Inc. reserves the right to change designs and specifications without notice or liability for such changes. Please contact Powers Fasteners for the most current and up to date available information or refer to our website at www.powers.com

Powers Fasteners 2 Powers Lane, Brewster, NY 10509 P: (914) 235-6300 F: (914) 576-6483
Powers Fasteners Canada Ltd. 6950 Edwards Boulevard Mississauga Ontario L5T-2W2 Canada
P: (905) 673-7295 or 1-800-387-3480 F: (905) 673-6490

**Jobsite
Assistance
24/7**



www.powers.com

Cat. No. 49074 09/10
©2010 Powers Fasteners, Inc.