

BOARD OF
BUILDING AND SAFETY
COMMISSIONERS

MARSHA L. BROWN
PRESIDENT

VAN AMBATIELOS
VICE-PRESIDENT

VICTOR H. CUEVAS
HELENA JUBANY
ELENORE A. WILLIAMS

CITY OF LOS ANGELES
CALIFORNIA



ANTONIO R. VILLARAIGOSA
MAYOR

DEPARTMENT OF
BUILDING AND SAFETY
201 NORTH FIGUEROA STREET
LOS ANGELES, CA 90012

ROBERT R. "BUD" OVROM
GENERAL MANAGER

RAYMOND S. CHAN, P.E., S.E.
EXECUTIVE OFFICER

Powers Fasteners, Inc.
2 Powers Lane
Brewster, New York 10509

Attn: Brian Schutz
(914) 235-6300

RESEARCH REPORT: RR 25787
(CSI # 03151)

BASED UPON ICC ES EVALUATION SERVICE
REPORT NO. ESR-2818

REEVALUATION DUE
DATE: June 1, 2014
Issued Date : May 1, 2011
Code: 2011 LABC

GENERAL APPROVAL –Reevaluation/Clerical Modification - Powers Power-Stud+ SD1
Expansion Anchors for Cracked and Uncracked Concrete.

DETAILS

The above assemblies and/or products are approved when in compliance with the description, use, identification and findings of ICC Evaluation Services Report No. ESR-2818, reissued December 1, 2009, revised February 2011, of the ICC Evaluation Service, Incorporated. The report in its entirety is attached and made part of this general approval.

The parts of Report No. ESR-2818 which are excluded on the attached copy have been removed by the City of Los Angeles Department of Building and Safety as not being included in this approval.

The approval is subject to the following conditions:

1. The allowable and strength design values listed in the attached report and tables are for the fasteners only. Connected members shall be checked for capacity (which may govern).
2. The anchors shall be identified by labels on the packaging indicating the manufacturer's name and product designation.

RR 25787
Page 1 of 3

Powers Fasteners, Inc.

Re: Powers Power-Stud+ SD1 Expansion Anchors for Cracked and Uncracked Concrete.

3. The anchors shall be installed as per the attached manufacturer's instructions except as otherwise stated in this report. Copies of the installation instructions shall be available at each job site.
4. Design values and minimum embedment requirements shall be per Tables in ICC ES Report No. ESR-2818.
5. The concrete shall have attained its minimum design strength prior to installation of the anchors.
6. Special inspection in accordance with Section 1704 of the 2011 Los Angeles City Building Code shall be provided for anchor installations.
7. The use of anchors is limited to dry interior locations.
8. The anchors are not approved for masonry application.
9. Calculations demonstrating that the applied loads or factored loads are less than the allowable load values or design strength level values respectively, described in this report shall be submitted to the plan check Engineer at the time of permit application. The calculations shall be prepared by a Civil or Structural Engineer registered in the State of California.

EXCEPTION: Anchors used for the installation of mechanical, plumbing and electrical equipment may be designed and detailed on a plan prepared by an engineer licensed by the state of California.

DISCUSSION

The clerical modification is to change the contact person.

The report is in compliance with the 2011 Los Angeles City Building Code.

The approval is based on tests in accordance with ICC ES Acceptance Criteria for Mechanical Anchors in Concrete Elements (AC 193), dated February 2009, which incorporate requirements in ACI 355.2-04, for use in cracked and uncracked concrete; including optional suitability Test 12 and 13 (AC 193, Table 4.2) for seismic tension and shear, and quality control documentation.

This general approval will remain effective provided the Evaluation Report is maintained valid and unrevised with the issuing organization. Any revision to the report must be submitted to this Department for review with appropriate fee to continue the approval of the revised report.

Addressee to whom this Research Report is issued is responsible for providing copies of it, complete with any attachments indicated, to architects, engineers and builders using items approved herein in design or construction which must be approved by Department of Building and Safety Engineers and Inspectors.

Powers Fasteners, Inc.

Re: Powers Power-Stud+ SD1 Expansion Anchors for Cracked and Uncracked Concrete.

This general approval of an equivalent alternate to the Code is only valid where an engineer and/or inspector of this Department has determined that all conditions of this Approval have been met in the project in which it is to be used.

Powers Fasteners offers software to assist in the design of anchorages using Powers Fasteners products. The software "PDA Powers Design Assist" includes selectable Strength Design methodology utilizing ICC-ES AC193-compliant data to generate designs in conformance with the 2011 Los Angeles City Building Code. The PDA Software may be downloaded at www.Powers.com.

WILLIAM STUTSMAN, Chief
Engineering Research Section
201 N. Figueroa St., Room 880
Los Angeles, CA 90012
Phone- 213-202-9812
Fax- 213-202-9943

KH:kh
RR25787/MSWord2007
R04/19/11
5A1/1912

Attachment: ICC ES Report No. ESR-2818 (10 Pages)

ICC-ES Evaluation Report

ESR-2818*

Reissued December 1, 2009

This report is subject to re-examination in one year.

www.icc-es.org | (800) 423-6587 | (562) 699-0543

A Subsidiary of the International Code Council®

DIVISION: 03 00 00—CONCRETE
Section: 03 16 00—Concrete Anchors
REPORT HOLDER:
POWERS FASTENERS, INC.
 2 POWERS LANE
 BREWSTER, NEW YORK 10509
 (914) 235-6300 or (800) 524-3244
www.powers.com
engineering@powers.com
ADDITIONAL LISTEES:
COOPER B-LINE, INC.
 509 WEST MONROE STREET
 HIGHLAND, ILLINOIS 62249
blineus@cooperindustries.com
L. H. DOTTIE COMPANY
 6131 SOUTH GARFIELD AVENUE
 COMMERCE, CALIFORNIA 90040
lane@lhdottie.com
THE HILLMAN GROUP
 10590 HAMILTON AVENUE
 CINCINNATI, OHIO 45231
info@hillmangroup.com
EVALUATION SUBJECT:
**POWERS POWER-STUD+ SD1 EXPANSION ANCHORS
 FOR CRACKED AND UNCRACKED CONCRETE**
1.0 EVALUATION SCOPE
Compliance with the following codes:

- 2009 *International Building Code*® (2009 IBC)
- 2009 *International Residential Code*® (2009 IRC)
- 2006 *International Building Code*® (2006 IBC)
- * ■ ~~2006 *International Residential Code*® (2006 IRC)~~ *
- ~~2003 *International Building Code*® (2003 IBC)~~
- ~~2003 *International Residential Code*® (2003 IRC)~~
- * ■ ~~1997 *Uniform Building Code*™ (UBC)~~ *

Property evaluated:

Structural

2.0 USES

The Powers Power-Stud+ SD1 expansion anchors are used to resist static, wind and seismic tension and shear loads in cracked and uncracked normal-weight concrete and structural sand-lightweight concrete having a specified compressive strength, f'_c , of 2,500 psi to 8,500 psi (17.2 MPa to 58.6 MPa); and cracked and uncracked normal-weight or structural sand-lightweight concrete over steel deck having a minimum specified compressive strength, f'_c , of 3,000 psi (20.7 MPa).

The Power-Stud+ SD1 expansion anchors comply with Section 1912 of the 2009 or 2006 IBC, as applicable, ~~and Section 1913 of the 2003 IBC, and are alternatives to cast-in-place anchors described in Sections 1923.1 and 1923.2 of the UBC.~~ The anchors may also be used where an engineered design is submitted in accordance with Section R301.1.3 of the 2009, ~~2006 and 2003~~ IRC.

3.0 DESCRIPTION
3.1 Power-Stud+ SD1:

Power-Stud+ SD1 expansion anchors are torque-controlled, mechanical expansion anchors comprised of an anchor body, expansion wedge (clip), washer and hex nut. Product names corresponding to report holder and additional listees are presented in Table A of this report. Available diameters are 1/4 inch, 3/8 inch, 1/2 inch, 5/8 inch, 3/4 inch and 1 inch (6.4 mm, 9.5 mm, 12.7 mm, 15.9 mm, 19.1 mm and 25.4 mm). The anchor body and expansion clip are manufactured from medium carbon steel complying with requirements set forth in the approved quality documentation, and have minimum 0.0002-inch-thick (5 µm) zinc plating in accordance with ASTM B 633. The washers comply with ASTM F 844. The hex nuts comply with ASTM A 563, Grade A. The Power-Stud+ SD1 expansion anchor is illustrated in Figure 2.

The anchor body is comprised of a high-strength threaded rod at one end and a tapered mandrel at the other end. The tapered mandrel is enclosed by a three-section expansion clip that freely moves around the mandrel. The expansion clip movement is restrained by the mandrel taper and by a collar. The anchors are installed in a predrilled hole with a hammer. When torque is applied to the nut of the installed anchor on the threaded end of the anchor body, the mandrel at the other end of the anchor is drawn into the expansion clip, forcing it outward into the sides of the predrilled hole in the base material.

3.2 Concrete:

Normal-weight and structural sand-lightweight concrete must comply with Sections 1903 and 1905 of the IBC ~~or UBC as applicable.~~

*Revised February 2011

3.3 Steel Deck Panels:

Steel deck panels must comply with the configuration in Figure 4 and have a minimum base steel thickness of 0.035 inch (0.889 mm) [No. 20 gage]. Steel must comply with ASTM A 653/A 653M SS Grade 36, and have a minimum yield strength of 36 ksi (248 MPa).

4.0 DESIGN AND INSTALLATION

4.1 Strength Design:

Anchor design strengths must be determined in accordance with ACI 318-08 (2009 IBC) or ACI 318-05 (2006 IBC), as applicable, using the design parameters provided in Tables 3 and 4 of this report. Design strengths must be determined in accordance with ACI 318-08 for compliance with (or an alternative under) the 2003 IBC and the UBC, and Section R301.1 of the IRC. Design parameters are based on the 2009 IBC (ACI 318-08) unless noted otherwise in this report. The anchor design must satisfy the requirements in ACI 318 D.4.1.1 and D.4.1.2. Strength reduction factors, ϕ , described in ACI 318 D.4.4, and listed in Tables 3 and 4 of this report, must be used for load combinations calculated in accordance with Section 1605.2.1 of the IBC, Section 9.2 of ACI 318, or Section 1612.2.1 of the UBC. Strength reduction factors, ϕ , described in ACI 318 D.4.5 must be used for load combinations calculated in accordance with Appendix C of ACI 318 or Section 1909.2 of the UBC. Strength reduction factors, ϕ , corresponding to ductile steel elements may be used. An example calculation is provided in Figure 5.

4.1.1 Requirements for Static Steel in Tension, N_{sa} :

The nominal static steel strength of a single anchor in tension calculated in accordance with ACI 318 D.5.1.2, N_{sa} , is given in Table 3 of this report.

4.1.2 Requirements for Static Concrete Breakout Strength in Tension, N_{cb} or N_{cbg} :

The nominal concrete breakout strength of a single anchor or a group of anchors in tension, N_{cb} and N_{cbg} , respectively must be calculated in accordance with ACI 318 D.5.2, with modifications as described in this section. The basic concrete breakout strength in tension, N_b , must be calculated in accordance with ACI 318 D.5.2, using the values of h_{ef} and k_{cr} as given in Table 3 of this report. The nominal concrete breakout strength in tension in regions where analysis indicates no cracking in accordance with ACI 318 D.5.2.6 must be calculated with the value of k_{uncr} as given in Table 3 and with $\psi_{c,N} = 1.0$.

For anchors installed in the soffit of structural sand-lightweight or normal-weight concrete-filled steel deck floor and roof assemblies, as shown in Figure 4, calculation of the concrete breakout strength in accordance with ACI 318 D.5.2 is not required.

4.1.3 Requirements for Static Pullout Strength in Tension, N_{pn} :

The nominal pullout strength of a single anchor in accordance with ACI D.5.3.1 and D.5.3.2 in cracked and uncracked concrete, $N_{p,cr}$, and $N_{p,uncr}$, respectively, is given in Table 3. In lieu of ACI 318 D.5.3.6, $\psi_{c,P} = 1.0$ for all design cases. The nominal pullout strength in cracked concrete may be adjusted by calculations according to Eq-1:

$$N_{pn,f'_c} = N_{p,cr} \left(\frac{f'_c}{2,500} \right)^{0.5} \quad (lb, \text{psi}) \quad \text{(Eq-1)}$$

$$N_{pn,f'_c} = N_{p,cr} \left(\frac{f'_c}{17.2} \right)^{0.5} \quad (N, \text{MPa})$$

where f'_c is the specified concrete compressive strength.

In regions where analysis indicates no cracking in accordance with ACI 318 D.5.3.6, the nominal pullout strength in tension can be adjusted by

$$N_{pn,f'_c} = N_{p,uncr} \left(\frac{f'_c}{2,500} \right)^{0.5} \quad (lb, \text{psi}) \quad \text{(Eq-2)}$$

$$N_{pn,f'_c} = N_{p,uncr} \left(\frac{f'_c}{17.2} \right)^{0.5} \quad (N, \text{MPa})$$

where f'_c is the specified concrete compressive strength.

Where values for $N_{p,cr}$ or $N_{p,uncr}$ are not provided in Table 3 of this report, the pullout strength in tension need not be evaluated.

The nominal pullout strength in tension of the anchors installed in the soffit of structural sand-lightweight or normal weight concrete-filled steel deck floor and roof assemblies, as shown in Figure 4, is provided in Table 3. In accordance with ACI 318 D.5.3.2, the nominal pullout strength in cracked concrete must be calculated according to Eq-1, whereby the value of $N_{p,deck,cr}$ must be substituted for $N_{p,cr}$ and the value of 3,000 psi or 20.7 MPa must be substituted for the value of 2,500 psi or 17.2 MPa in the denominator. In regions where analysis indicates no cracking in accordance with ACI 318 D.5.3.6, the nominal strength in uncracked concrete must be calculated according to Eq-2, whereby the value of $N_{p,deck,uncr}$ must be substituted for $N_{p,uncr}$ and the value of 3,000 psi or 20.7 MPa must be substituted for the value of 2,500 psi or 17.2 MPa in the denominator.

4.1.4 Requirements for Static Steel Shear Capacity, V_{sa} :

The nominal steel strength in shear, V_{sa} , of a single anchor in accordance with ACI 318 D.6.1.2 is given in Table 4 of this report and must be used in lieu of the values derived by calculation from ACI 318, Eq. D-20. The strength reduction factor, ϕ , corresponding to a ductile steel element must be used for all anchors, as described in Table 4 of this report. The shear strength $V_{sa,deck}$ of anchors installed in the soffit of structural sand-lightweight or normal-weight concrete on steel deck floor and roof assemblies, as shown in Figure 4, is given in Table 4 of this report.

4.1.5 Requirements for Static Concrete Breakout Strength in Shear, V_{cb} or V_{cbg} :

The nominal concrete breakout strength of a single anchor or group of anchors in shear, V_{cb} or V_{cbg} , respectively, must be calculated in accordance with ACI 318 D.6.2, with modifications as described in this section. The basic concrete breakout strength in shear, V_b , must be calculated in accordance with ACI 318 D.6.2.2 using the values of ℓ_e and d_o (d_a) given in Table 4 of this report.

For anchors installed in the soffit of structural sand-lightweight or normal-weight concrete-filled steel deck floor and roof assemblies, as shown in Figure 4, calculation of the concrete breakout strength in accordance with ACI 318 D.6.2 is not required.

4.1.6 Requirements for Static Concrete Pryout Strength in Shear, V_{cp} or V_{cpg} :

The nominal concrete pryout strength of a single anchor or group of anchors, V_{cp} or V_{cpg} , respectively, must be calculated in accordance with ACI 318 D.6.3, modified by using the value of K_{cp} provided in Table 4 and the value of N_{cb} or N_{cbg} as calculated in Section 4.1.2 of this report.

For anchors installed in the soffit of structural sand-lightweight or normal-weight concrete-filled steel deck floor and roof assemblies, as shown in Figure 4, calculation of the concrete pryout strength in accordance with ACI 318 D.6.3 is not required.

4.1.7 Requirements for Seismic Design:

4.1.7.1 General: For load combinations including seismic, the design must be performed in accordance with ACI 318 D.3.3, as modified by Section 1908.1.9 of the 2009 IBC or Section 1908.1.16 of the 2006 IBC, as applicable, or the following:

CODE	ACI 318 D.3.3 SEISMIC REGION	CODE EQUIVALENT DESIGNATION
2003 IBC and 2003 IRC	Moderate or high seismic risk	Seismic Design Categories C, D, E, and F
UBC	Moderate or high seismic risk	Seismic Zones 2B, 3 and 4

The nominal steel strength and nominal concrete breakout strength for anchors in tension, and the nominal concrete breakout strength and pryout strength for anchors in shear, must be calculated in accordance with ACI 318 D.5 and D.6, respectively, taking into account the corresponding values in Tables 3 and 4. The anchors comply with ACI 318 D.1 as ductile steel elements and must be designed in accordance with ACI 318-08 D.3.3.4, D.3.3.5 or D.3.3.6 or ACI 318-05 D.3.3.4 or D.3.3.5, as applicable. The 1/4-inch-diameter (6.4 mm) anchors must be limited to installation in regions designated as IBC Seismic Design Categories A and B only, or UBC Seismic Zones 0, 1, and 2A. The 3/8-inch-diameter (9.5 mm), 1/2-inch-diameter (12.7 mm), 5/8-inch-diameter (15.9 mm), 3/4-inch-diameter (19.1 mm) and 1-inch-diameter (25.4 mm) anchors may be installed in regions designated as IBC Seismic Design Categories A to F or UBC Seismic Zones 0 to 4.

4.1.7.2 Seismic Tension: The nominal steel strength and nominal concrete breakout strength for anchors in tension must be calculated in accordance with ACI 318 D.5.1 and D.5.2, as described in Sections 4.1.1 and 4.1.2 of this report. In accordance with ACI 318 D.5.3.2, the appropriate value for pullout strength in tension for seismic loads, N_{eq} or $N_{p,deck,cr}$, described in Table 3 must be used in lieu of N_p . N_{eq} or $N_{p,deck,cr}$ may be adjusted by calculations for concrete compressive strength in accordance with Eq-1 of this report. In addition, for structural sand-lightweight or normal-weight concrete-filled steel deck floor and roof assemblies, the value of 3,000 psi or 20.7 MPa must be substituted for the value of 2,500 psi or 17.2 MPa in the denominator.

Where values for N_{eq} or $N_{p,deck,cr}$ are not provided in Table 3 of this report, the pullout strength in tension for seismic loads need not be evaluated.

4.1.7.3 Seismic Shear: The nominal concrete breakout strength and pryout strength for anchors in shear must be calculated according to ACI 318 D.6.2 and D.6.3, as described in Sections 4.1.5 and 4.1.6. In accordance with ACI 318 D.6.1.2, the appropriate value for nominal steel strength in shear for seismic loads, V_{eq} or $V_{sa,deck,cr}$, described in Table 4 must be used in lieu of V_{sa} .

4.1.8 Requirements for Interaction of Tensile and Shear Forces: Anchors or groups of anchors that are subject to the effects of combined axial (tensile) and shear forces must be designed in accordance with ACI 318 D.7.

4.1.9 Requirements for Critical Edge Distance: In applications where $c < c_{ac}$ and supplemental reinforcement to control splitting of the concrete is not present, the concrete breakout strength in tension for uncracked concrete, calculated according to ACI 318 D.5.2, must be further multiplied by the factor $\psi_{cp,N}$ given by Eq-3:

$$\psi_{cp,N} = \frac{c}{c_{ac}} \tag{Eq-3}$$

where the factor $\psi_{cp,N}$ need not be taken as less than $\frac{1.5h_{ef}}{c_{ac}}$. For all other cases, $\psi_{cp,N} = 1.0$. In lieu of using ACI 318 D.8.6, values of c_{ac} must comply with Table 3.

4.1.10 Requirements for Minimum Member Thickness, Minimum Anchor Spacing and Minimum Edge Distance: In lieu of ACI 318 D.8.3, values of c_{min} and s_{min} must comply with Table 1. In lieu of ACI 318 D.8.5, minimum member thicknesses, h_{min} , must comply with Table 1. For anchors installed through the soffit of steel deck assemblies, the anchors must be installed in accordance with Figure 4 and must have an axial spacing along the flute equal to the greater of $3h_{ef}$ or 1.5 times the flute width.

4.1.11 Structural Sand-lightweight Concrete: For ACI 318-08, when anchors are used in structural sand-lightweight concrete, the modification factor λ for concrete breakout strength must be taken as 0.6. In addition, the pullout strength N_{puncr} , N_{pcr} , and N_{eq} must be multiplied by 0.6, as applicable.

For ACI 318-05, the values N_b , N_{puncr} , N_{pcr} , N_{eq} , and V_b determined in accordance with this report must be multiplied by 0.60 in lieu of ACI 318 D.3.4.

For anchors installed in the soffit of structural sand-lightweight concrete-filled steel deck floor and roof assemblies, this reduction is not required.

4.2 Allowable Stress Design (ASD):

4.2.1 General: Design values for use with allowable stress design load combinations calculated in accordance with Section 1605.3 of the IBC and Section 1612.3 of the UBC, must be established using Eq-4 and Eq-5:

$$T_{allowable,ASD} = \frac{\phi N_n}{\alpha} \tag{Eq-4}$$

$$V_{allowable,ASD} = \frac{\phi V_n}{\alpha} \tag{Eq-5}$$

where:

$T_{allowable,ASD}$ = Allowable tension load (lbf or kN)

$V_{allowable,ASD}$ = Allowable shear load (lbf or kN)

ϕN_n = Lowest design strength of an anchor or anchor group in tension as determined in accordance with ACI 318 Appendix D, Section 4.1 of this report, and 2009 IBC Section 1908.1.9 or 2006 IBC Section 1908.1.16, as applicable (lbf or N).

ϕV_n = Lowest design strength of an anchor or anchor group in shear as determined in accordance with ACI 318 Appendix D, Section 4.1 of this report, and 2009 IBC Section 1908.1.9 or 2006 IBC Section 1908.1.16, as applicable (lbf or N).

α = Conversion factor calculated as a weighted average of the load factors for the controlling load combination. In addition, α must include all applicable factors to account for nonductile failure modes and required over-strength.

The requirements for member thickness, edge distance and spacing, described in this report, must apply. An example of allowable stress design values for illustrative purposes is shown in Table 5.

4.2.2 Interaction of Tensile and Shear Forces: The interaction must be calculated and consistent with ACI 318 D.7 as follows:

For shear loads $V \leq 0.2V_{allowable,ASD}$, the full allowable load in tension must be permitted.

For tension loads $T \leq 0.2T_{allowable,ASD}$, the full allowable load in shear must be permitted.

For all other cases Eq-6 applies:

$$\frac{T}{T_{allowable,ASD}} + \frac{V}{V_{allowable,ASD}} \leq 1.2 \quad (\text{Eq-6})$$

4.3 Installation:

Installation parameters are provided in Table 1, Figure 1 and Figure 4. Anchor locations must comply with this report and the plans and specifications approved by the code official. The Power-Stud+ SD1 expansion anchors must be installed in accordance with the manufacturer's published installation instructions and this report. Anchors must be installed in holes drilled into the concrete using carbide-tipped masonry drill bits complying with ANSI B212.15-1994. The nominal drill bit diameter must be equal to that of the anchor. The minimum drilled hole depth is given in Table 1. Prior to anchor installation, the dust and debris must be removed from the predrilled hole using a hand pump, compressed air or vacuum. The anchor must be hammered into the predrilled hole until the proper nominal embedment depth is achieved. The nut must be tightened against the washer until the torque values specified in Table 1 are achieved.

For installation in the soffit of concrete on steel deck assemblies, the hole diameter in the steel deck must be no more than $1/8$ -inch (3.2 mm) larger than the diameter of the hole in the concrete. Member thickness and edge distance restrictions for installations into the soffit of concrete on steel deck assemblies must comply with Figure 4.

4.4 Special Inspection:

Special inspection is required in accordance with Section 1704.13 of the IBC ~~and, as applicable, Section 1701.5.2 of the UBC.~~ * The special inspector must make periodic inspections during anchor installation to verify anchor type, anchor dimensions, concrete type, concrete compressive strength, drill bit type, hole dimensions, hole cleaning procedure, concrete member thickness, anchor embedment, anchor spacing, edge distances, tightening torque and adherence to the manufacturer's printed installation instructions. The special inspector must be present as often as required in accordance with the "statement of special inspection." Under the IBC, additional requirements as set forth in Sections 1705 and 1706 must be observed, where applicable.

5.0 CONDITIONS OF USE

The Powers Power-Stud+ SD1 expansion anchors described in this report comply with, or are suitable alternatives to what is specified in, those codes listed in Section 1.0 of this report, subject to the following conditions:

- 5.1 The anchors must be installed in accordance with the manufacturer's published installation instructions and this report. In case of conflict, this report governs.
- 5.2 Anchor sizes, dimensions, and minimum embedment depths are as set forth in this report.

5.3 Anchors must be installed in uncracked concrete and structural sand-lightweight concrete [$1/4$ -inch (6.4 mm) anchors]; in cracked and uncracked normal-weight concrete and structural sand-lightweight concrete [$3/8$ -inch to 1-inch anchors (9.5 mm to 25.4 mm)] having a specified compressive strength, f'_c , of 2,500 psi to 8,500 psi (17.2 MPa to 58.6 MPa); and cracked and uncracked normal-weight or structural sand-lightweight concrete-filled steel deck [$3/8$ -inch to $3/4$ -inch anchors (9.5 mm and 19.1 mm)] having a minimum specified compressive strength, f'_c , of 3,000 psi (20.7 MPa).

5.4 The values of f'_c used for calculation purposes must not exceed 8,000 psi (55.2 MPa).

5.5 Strength design values must be established in accordance with Section 4.1 of this report.

5.6 Allowable design values must be established in accordance with Section 4.2 of this report.

5.7 Anchor spacing(s) and edge distance(s), as well as minimum member thickness, must comply with Table 1 and Figure 4 of this report, unless otherwise noted.

5.8 Prior to installation, calculations and details demonstrating compliance with this report must be submitted to the code official. The calculations and details must be prepared by a registered design professional where required by the statutes of the jurisdiction in which the project is to be constructed.

5.9 Since an ICC-ES acceptance criteria for evaluating data to determine the performance of anchors subjected to fatigue or shock loading is unavailable at this time, the use of these anchors under such conditions is beyond the scope of this report.

5.10 Anchors [except $1/4$ -inch-diameter (6.4 mm)] may be installed in regions of concrete where cracking has occurred or where analysis indicates cracking may occur ($f_t > f_r$), subject to the conditions of this report.

5.11 The $1/4$ -inch-diameter (6.4 mm) anchors may be used to resist short-term loading due to wind forces, and for seismic load combinations limited to locations designated as Seismic Design Categories A and B, under the IBC, ~~and Seismic Zones 0, 1, and 2A under the UBC,~~ * subject to the conditions of this report. The $3/8$ -inch- to 1-inch-diameter (9.5 mm to 25.4 mm) anchors may be used to resist short-term loading due to wind or seismic forces in locations designated as Seismic Design Categories A through F, under the IBC, ~~and Seismic Zones 0 through 4 under the UBC,~~ * subject to the conditions of this report.

5.12 Where not otherwise prohibited in the code, Power-Stud+ SD1 expansion anchors are permitted for use with fire-resistance-rated construction provided that at least one of the following conditions is fulfilled:

- The $1/4$ -inch-diameter (6.4 mm) anchors are used to resist wind forces or seismic forces in regions as set forth in Section 5.11 of this report only. The $3/8$ -inch to 1-inch-diameter (9.5 mm to 25.4 mm) anchors are used to resist wind or seismic forces only.
- Anchors that support a fire-resistance-rated envelope or a fire-resistance-rated membrane are protected by approved fire-resistance-rated materials, or have been evaluated for resistance to fire exposure in accordance with recognized standards.
- Anchors are used to support nonstructural elements.

- 5.13 Use of carbon steel anchors is limited to dry, interior locations.
- 5.14 Special inspection must be provided in accordance with Section 4.4 of this report.
- 5.15 Anchors are manufactured under an approved quality control program with inspections by CEL Consulting (AA-639).

6.0 EVIDENCE SUBMITTED

Data in accordance with the ICC-ES Acceptance Criteria for Mechanical Anchors in Concrete Elements (AC193), dated October 2009, which incorporate requirements in ACI 355.2-07 / ACI 355.2-04, for use in cracked and uncracked concrete; including optional suitability tests for seismic tension and shear; and quality control documentation.

7.0 IDENTIFICATION

The Power-Stud+ SD1 expansion anchors are identified by dimensional characteristics and packaging. A length letter code is stamped on each anchor on the exposed threaded stud end along with the number “1” which is visible after installation. Table 2 summarizes the length code identification system. A plus sign “+” is also marked with the number “1” on all anchors with the exception of the 1/4-inch-diameter (6.4 mm) anchors. Packages are identified with the product name, type and size, the company name as set forth in Table A of this report, the name of the inspection agency (CEL) and the evaluation report number (ICC-ES ESR-2818).

TABLE A—CROSS REFERENCE OF PRODUCT NAMES TO COMPANY NAMES

COMPANY NAME	PRODUCT NAME
Powers Fasteners, Inc.	Power-Stud+ SD1
Cooper B-Line	Cooper B-Line Wedge Anchor
L. H. Dottie Co.	Dottie Wedge SD1
The Hillman Group	Hillman Power-Stud+ SD1

TABLE B—MEAN AXIAL STIFFNESS VALUES, β , FOR POWER-STUD+ SD1 EXPANSION ANCHORS IN NORMAL-WEIGHT CONCRETE¹

CONCRETE STATE	UNITS	NOMINAL ANCHOR DIAMETER					
		1/4 inch	3/8 inch	1/2 inch	5/8 inch	3/4 inch	1 inch
Uncracked concrete	10 ³ lbf/in. (kN/mm)	110	188	141	200	200	600
		(19)	(33)	(25)	(35)	(35)	(103)
Cracked concrete	10 ³ lbf/in. (kN/mm)	-	26	30	50	51	129
			(4)	(5)	(9)	(9)	(23)

¹Mean values shown; actual stiffness varies considerably depending on concrete strength, loading and geometry of application.

TABLE 1—POWER-STUD+ SD1 ANCHOR INSTALLATION SPECIFICATIONS¹

Anchor Property/Setting Information	Notation	Units	Nominal Anchor Diameter							
			1/4 inch	3/8 inch	1/2 inch	5/8 inch	3/4 inch	1 inch		
Anchor diameter	$d_o(d_a)$ ⁵	in. (mm)	0.250 (6.4)	0.375 (9.5)	0.500 (12.7)	0.625 (15.9)	0.750 (19.1)	1.000 (25.4)		
Minimum diameter of hole clearance in fixture	d_h	in. (mm)	5/16 (7.5)	7/16 (11.1)	9/16 (14.3)	11/16 (17.5)	13/16 (20.6)	1 1/8 (28.6)		
Nominal drill bit diameter	d_{bit}	in. ANSI	1/4 ANSI	3/8 ANSI	1/2 ANSI	5/8 ANSI	3/4 ANSI	1 ANSI		
Minimum nominal embedment depth	h_{nom}	in. (mm)	1-3/4 (44)	2-3/8 (60)	2-1/2 (64)	3-3/4 (95)	3-3/8 (86)	4-5/8 (117)	4 (102)	5-1/2 (140)
Effective embedment	h_{ef}	in. (mm)	1.50 (38)	2.00 (51)	2.00 (51)	3.25 (83)	2.75 (70)	4.00 (102)	3.125 (79)	4.375 (111)
Minimum hole depth ²	h_o	in. mm	2 (51)	2-5/8 (67)	2-3/4 (70)	4 (102)	3-3/4 (95)	5 (127)	4-1/4 (108)	4 7/8 (124)
Minimum member thickness ²	h_{min}	in. (mm)	4 (102)	4 (102)	5 (127)	6 (152)	6 (152)	7 (178)	6 (152)	10 (254)
Minimum overall anchor length	l_{anch}	in. (mm)	2-1/4 (57)	3 (76)	3-3/4 (95)	5-1/2 (140)	4-1/2 (114)	6 (152)	5-1/2 (140)	9 (229)
Minimum edge distance ²	c_{min}	in. (mm)	1-3/4 (44)	2-1/4 (57)	5-1/4 (133)	4 (102)	5-1/2 (140)	4-1/4 (108)	5 (127)	8 (203)
Minimum spacing distance ²	s_{min}	in. (mm)	2-1/4 (57)	3-3/4 (95)	7-1/4 (184)	5 (127)	11 (270)	4-1/4 (108)	6 (152)	8 (203)
Critical edge distance ²	c_{ac}	in. (mm)	3-1/2 (89)	6-1/2 (165)	8-1/2 (216)	8 (203)	6 (152)	10 (254)	11 (279)	12 (305)
Installation torque ³	T_{inst}	ft.-lbf. (N-m)	4 (5)	20 (27)	40 (54)	80 (108)	110 (149)	225 (305)		
Torque wrench/socket size	-	in.	7/16	9/16	3/4	15/16	1-1/8	1-1/2		
Nut height	-	in.	7/32	21/64	7/16	35/64	41/64	55/64		

For SI: 1 inch = 25.4 mm, 1 ft-lbf = 1.356 N-m.

¹The information presented in this table is to be used in conjunction with the design criteria of ACI 318 Appendix D.

²For installations through the soffit of steel into concrete, see the installation detail. Anchors in the lower flute may be installed with a maximum 1-inch offset in either direction from the center of the flute. In addition, anchors must have an axial spacing along the flute equal to the greater of $3h_{ef}$ or 1.5 times the flute width.

³For installation of 5/8-inch diameter anchors through the soffit of the steel deck into concrete, the installation torque is 50 ft.-lbf. For installation of 3/4-inch-diameter anchors through the soffit of the steel deck into concrete, installation torque is 80 ft.-lbf.

⁴The listed minimum overall anchor length is based on anchor sizes commercially available at the time of publication compared with the requirements to achieve the minimum nominal embedment depth, nut height and washer thickness, and consideration of a possible fixture attachment.

⁵The notation in brackets is for the 2006 IBC.

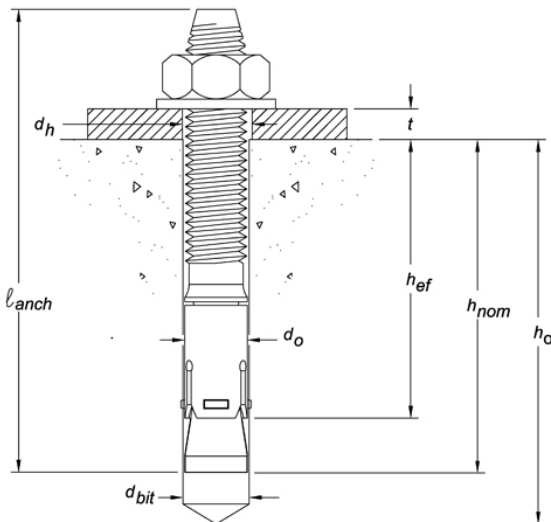

FIGURE 1—POWER-STUD+ SD1 ANCHOR DETAIL

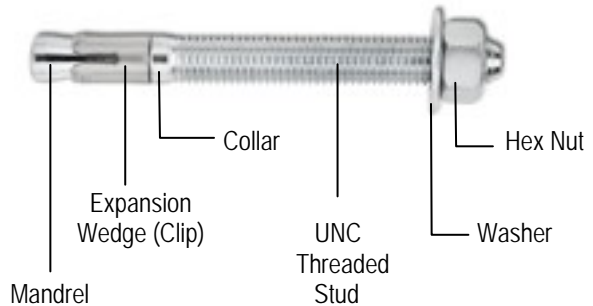
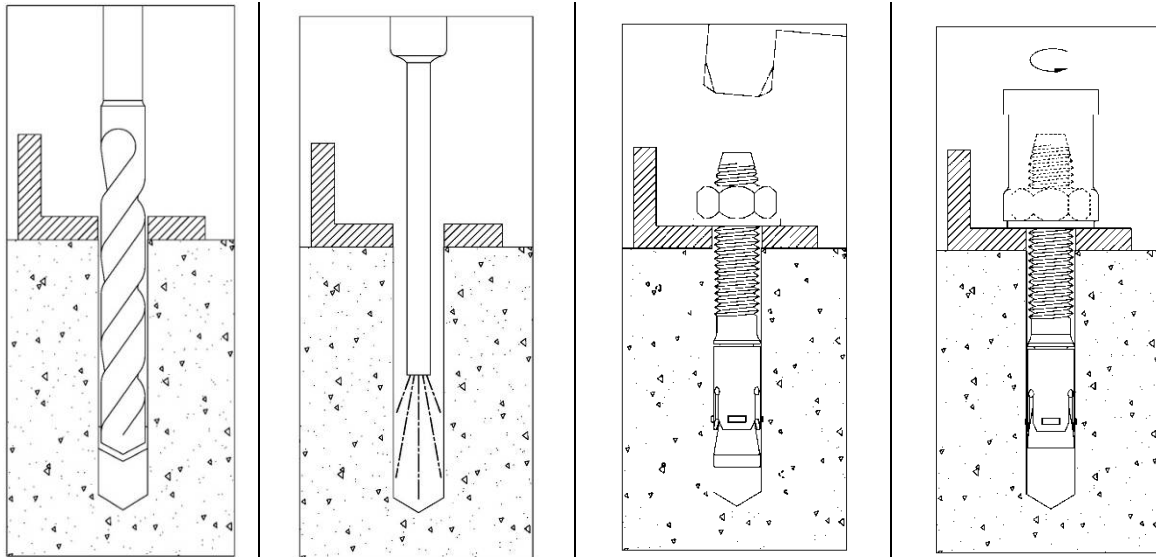

FIGURE 2—POWER-STUD+ SD1 ANCHOR ASSEMBLY



1.) Using the proper drill bit size, drill a hole into the base material to the required depth. The tolerances of the drill bit used should meet the requirements of ANSI Standard B212.15.

2.) Remove dust and debris from the hole using a hand pump, compressed air or a vacuum to remove loose particles left from drilling.

3.) Position the washer on the anchor and thread on the nut. If installing through a fixture, drive the anchor through the fixture into the hole. Be sure the anchor is driven to the minimum required embedment depth, h_{nom} .

4.) Tighten the anchor with a torque wrench by applying the required installation torque, T_{inst} . (See Table 1.)

FIGURE 3—POWER-STUD+ SD1 INSTALLATION INSTRUCTIONS

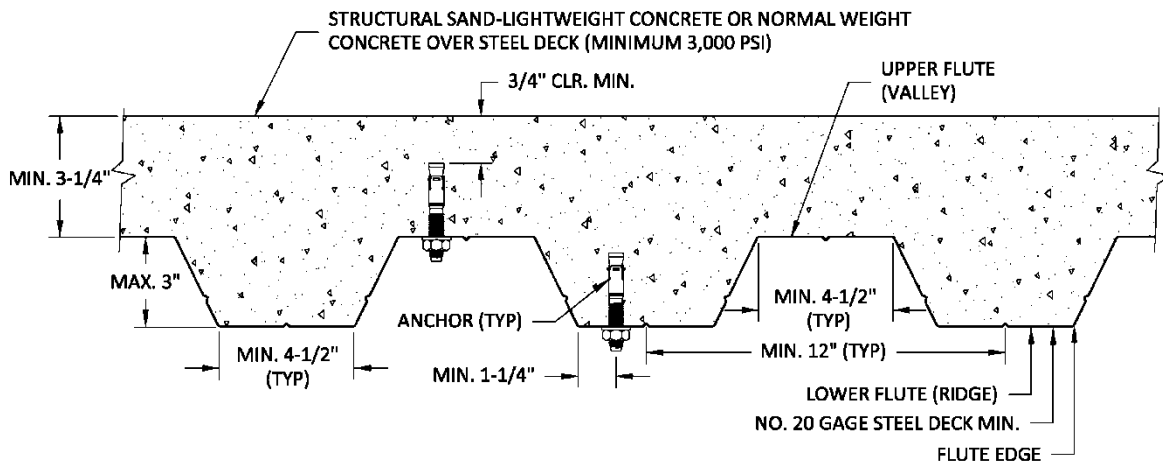

FIGURE 4—POWER-STUD+ SD1 INSTALLATION DETAIL FOR ANCHORS IN THE SOFFIT OF CONCRETE OVER STEEL DECK FLOOR AND ROOF ASSEMBLIES

TABLE 2—POWER-STUD+ SD1 ANCHOR LENGTH CODE IDENTIFICATION SYSTEM

Length ID marking on threaded stud head	A	B	C	D	E	F	G	H	I	J	K	L	M	N	O	P	Q	R	S	T	
Overall anchor length, l_{anch} (inches)	From	1 1/2	2	2 1/2	3	3 1/2	4	4 1/2	5	5 1/2	6	6 1/2	7	7 1/2	8	8 1/2	9	9 1/2	10	11	12
	Up to but not including	2	2 1/2	3	3 1/2	4	4 1/2	5	5 1/2	6	6 1/2	7	7 1/2	8	8 1/2	9	9 1/2	10	11	12	13

For **SI**: 1 inch = 25.4 mm.

TABLE 3—TENSION DESIGN INFORMATION FOR POWER-STUD+ SD1 ANCHOR IN CONCRETE
(For use with load combinations taken from ACI 318, Section 9.2)^{1,2}

Design Characteristic	Notation	Units	Nominal Anchor Diameter							
			¹ / ₄ inch	³ / ₈ inch	¹ / ₂ inch	⁵ / ₈ inch	³ / ₄ inch	1 inch		
Anchor category	1, 2 or 3	-	1	1	1	1	1	1	1	
STEEL STRENGTH IN TENSION⁴										
Minimum specified yield strength	f_y	ksi (N/mm ²)	88.0 (606)	88.0 (606)	80.0 (551)	80.0 (551)	58.0 (400)	58.0 (400)		
Minimum specified ultimate tensile strength (neck)	f_{uta}^{11}	ksi (N/mm ²)	110.0 (758)	110.0 (758)	100.0 (689)	100.0 (689)	75.0 (517)	75.0 (517)		
Effective tensile stress area (neck)	$A_{se,N}$ [A_{se}] ¹²	in ² (mm ²)	0.0220 (14.2)	0.0531 (34.3)	0.1018 (65.7)	0.1626 (104.9)	0.2376 (150.9)	0.4300 (273.1)		
Steel strength in tension	N_{sa}^{11}	lb (kN)	2,255 (10.0)	5,455 (24.3)	9,080 (40.4)	14,465 (64.3)	17,820 (79.3)	32,250 (143.5)		
Reduction factor for steel strength ³	ϕ	-	0.75							
CONCRETE BREAKOUT STRENGTH IN TENSION⁸										
Effective embedment	h_{ef}	in. (mm)	1.50 (38)	2.00 (51)	2.00 (51)	3.25 (83)	2.75 (70)	4.00 (102)	3.125 (79)	4.375 (111)
Effectiveness factor for uncracked concrete	k_{uncr}	-	24	24	24	24	24	24	24	
Effectiveness factor for cracked concrete	k_{cr}	-	Not Applicable	17	17	17	17	24	24	
Modification factor for cracked and uncracked concrete ⁵	$\psi_{c,N}^{11}$	-	1.0 See note 5	1.0 See note 5	1.0 See note 5	1.0 See note 5	1.0 See note 5	1.0 See note 5	1.0 See note 5	
Critical edge distance	c_{ac}	in. (mm)	4 (102)	6- ¹ / ₂ (165)	8- ¹ / ₂ (216)	8 (203)	11 (280)	12 (305)	11 (280)	12 (305)
Reduction factor for concrete breakout strength ³	ϕ	-	0.65 (Condition B)							
PULLOUT STRENGTH IN TENSION (NON SEISMIC-APPLICATIONS)⁸										
Characteristic pullout strength, uncracked concrete (2,500 psi) ⁶	$N_{p,uncr}$	lb (kN)	See footnote 7	2,865 (12.8)	3,220 (14.3)	5,530 (24.6)	See note 7	See note 7	See note 7	See note 7
Characteristic pullout strength, cracked concrete (2,500 psi) ⁶	$N_{p,cr}$	lb (kN)	Not Applicable	2,035 (9.1)	See note 7	2,505 (11.2)	See note 7	4,450 (19.8)	See note 7	See note 7
Reduction factor for pullout strength ³	ϕ	-	0.65 (Condition B)							
PULLOUT STRENGTH IN TENSION FOR SEISMIC APPLICATIONS⁸										
Characteristic pullout strength, seismic (2,500 psi) ^{6,9}	N_{eq}^{11}	lb (kN)	Not Applicable	2,035 (9.1)	See note 7	2,505 (11.1)	See note 7	4,450 (19.8)	5,965 (26.5)	See note 7
Reduction factor for pullout strength, seismic ³	ϕ	-	0.65 (Condition B)							
PULLOUT STRENGTH IN TENSION FOR STRUCTURAL SAND-LIGHTWEIGHT AND NORMAL-WEIGHT CONCRETE OVER STEEL DECK										
Characteristic pullout strength, uncracked concrete over steel deck ^{6,10}	$N_{p,deck,uncr}$	lb (kN)	Not Applicable	1,940 (8.6)	3,205 (14.2)	2,795 (12.4)	3,230 (14.4)	Not Applicable		
Characteristic pullout strength, cracked concrete over steel deck ^{6,10}	$N_{p,deck,cr}$	lb (kN)	Not Applicable	1,375 (6.1)	2,390 (10.6)	1,980 (8.8)	3,230 (14.4)	Not Applicable		
Reduction factor for pullout strength, concrete over steel deck ³	ϕ	-	0.65 (Condition B)							

For SI: 1 inch = 25.4 mm; 1 ksi = 6.894 N/mm²; 1 lbf = 0.0044 kN.

¹The data in this table is intended to be used with the design provisions of ACI 318 Appendix D; for anchors resisting seismic load combinations the additional requirements of ACI 318 D.3.3 must apply.

²Installation must comply with published instructions and details.

³All values of ϕ apply to the load combinations of IBC Section 1605.2.1, ~~UBC Section 1612.2.1~~, or ACI 318 Section 9.2. If the load combinations of ~~UBC Section 1902.2~~ or ACI 318 Appendix C are used, the appropriate value of ϕ must be determined in accordance with ACI 318 D.4.5. For reinforcement that complies with ACI 318 Appendix D requirements for Condition A, the appropriate ϕ factor must be determined in accordance with ACI 318 D.4.4.

⁴The Power-Stud+ SD1 is considered a ductile steel element as defined by ACI 318 D.1. Tabulated values for steel strength in tension must be used for design.

⁵For all design cases use $\psi_{c,N} = 1.0$. The appropriate effectiveness factor for cracked concrete (k_{cr}) or uncracked concrete (k_{uncr}) must be used.

⁶For all design cases use $\psi_{c,p} = 1.0$. For the calculation of N_{pn} , see Section 4.1.3.

⁷Pullout strength does not control design of indicated anchors. Do not calculate pullout strength for indicated anchor size and embedment.

⁸Anchors are permitted to be used in structural sand-lightweight concrete in accordance with Section 4.1.11 of this report.

⁹Tabulated values for characteristic pullout strength in tension are for seismic applications and based on test results in accordance with ACI 355.2, Section 9.5.

¹⁰Values for $N_{p,deck}$ are for structural sand-lightweight concrete ($f'_{c,min} = 3,000$ psi) and additional lightweight concrete reduction factors need not be applied. In addition, evaluation for the concrete breakout capacity in accordance with ACI 318 D.5.2 is not required for anchors installed in the deck soffit (flute).

¹¹For 2003 IBC, f_{uta} replaces f_u ; N_{sa} replaces N_s ; $\psi_{c,N}$ replaces ψ_s and N_{eq} replaces $N_{p,seis}$.

¹²The notation in brackets is for the 2006 IBC.

TABLE 4—SHEAR DESIGN INFORMATION FOR POWER-STUD+ SD1 ANCHOR IN CONCRETE
(For use with load combinations taken from ACI 318, Section 9.2)^{1,2}

Design Characteristic	Notation	Units	Nominal Anchor Diameter							
			1/4 inch	3/8 inch	1/2 inch	5/8 inch	3/4 inch	1 inch		
Anchor category	1, 2 or 3	-	1	1	1	1	1	1	1	
STEEL STRENGTH IN SHEAR⁴										
Minimum specified yield strength (threads)	f_y	ksi (N/mm ²)	70.0 (482)	70.0 (482)	64.0 (441)	64.0 (441)	58.0 (400)	58.0 (400)		
Minimum specified ultimate strength (threads)	f_{uta}^{10}	ksi (N/mm ²)	88.0 (606)	88.0 (606)	80.0 (503)	80.0 (503)	75.0 (517)	75.0 (517)		
Effective tensile stress area (threads)	$A_{se,V}[A_{se}]^{11}$	in ² (mm ²)	0.0318 (20.5)	0.0775 (50.0)	0.1419 (91.5)	0.2260 (145.8)	0.3345 (212.4)	0.6060 (384.8)		
Steel strength in shear ⁵	V_{sa}^{10}	lb (kN)	915 (4.1)	2,120 (9.4)	3,520 (15.6)	4,900 (21.8)	6,860 (30.5)	10,935 (48.6)		
Reduction factor for steel strength ³	ϕ	-	0.65							
CONCRETE BREAKOUT STRENGTH IN SHEAR⁶										
Load bearing length of anchor (h_{ef} or $8d_o$, whichever is less)	ℓ_e^{10}	in. (mm)	1.50 (38)	2.00 (51)	2.00 (51)	3.25 (83)	2.75 (70)	4.00 (102)	3.125 (79)	4.375 (111)
Nominal anchor diameter	d_o (d_a)	in. (mm)	0.250 (6.4)	0.375 (9.5)	0.500 (12.7)	0.625 (15.9)	0.750 (19.1)	1.000 (25.4)		
Reduction factor for concrete breakout ³	ϕ	-	0.70 (Condition B)							
PRYOUT STRENGTH IN SHEAR⁶										
Coefficient for prout strength (1.0 for $h_{ef} < 2.5$ in., 2.0 for $h_{ef} \geq 2.5$ in.)	k_{cp}	-	1.0	1.0	1.0	2.0	2.0	2.0	2.0	2.0
Effective embedment	h_{ef}	in. (mm)	1.50 (38)	2.00 (51)	2.00 (51)	3.25 (83)	2.75 (70)	4.00 (102)	3.125 (79)	4.375 (111)
Reduction factor for prout strength ³	ϕ	-	0.70 (Condition B)							
STEEL STRENGTH IN SHEAR FOR SEISMIC APPLICATIONS										
Steel strength in shear, seismic ⁷	V_{eq}^{10}	lb (kN)	Not Applicable	2,120 (9.4)	3,520 (15.6)	4,900 (21.8)	5,695 (25.3)	9,845 (43.8)		
Reduction factor for steel strength in shear for seismic ³	ϕ	-	0.65							
STEEL STRENGTH IN SHEAR FOR STRUCTURAL SAND-LIGHTWEIGHT AND NORMAL-WEIGHT CONCRETE OVER STEEL DECK⁹										
Steel strength in shear, concrete over steel deck ⁸	$V_{sa,deck}$	lb (kN)	Not Applicable	2,120 (9.4)	2,290 (10.2)	3,710 (16.5)	5,505 (24.5)	Not Applicable		
Reduction factor for steel strength in shear for concrete over steel deck ³	ϕ	-	0.65							

For SI: 1 inch = 25.4 mm; 1 ksi = 6.894 N/mm²; 1 lbf = 0.0044 kN.

¹The data in this table is intended to be used with the design provisions of ACI 318 Appendix D; for anchors resisting seismic load combinations the additional requirements of ACI 318 D.3.3 must apply.

²Installation must comply with published instructions and details.

* ³All values of ϕ apply to the load combinations of IBC Section 1605.2.1, ~~UBC Section 1612.2.1~~, or ACI 318 Section 9.2. If the load combinations of ~~UBC Section 1902.2~~ or ACI 318 Appendix C are used, the appropriate value of ϕ must be determined in accordance with ACI 318 D.4.5. For reinforcement that complies with ACI 318 Appendix D requirements for Condition A, the appropriate ϕ factor must be determined in accordance with ACI 318 D.4.4.

⁴The Power-Stud+ SD1 is considered a ductile steel element as defined by ACI 318 D.1.

⁵Tabulated values for steel strength in shear must be used for design. These tabulated values are lower than calculated results using equation D-20 in ACI 318-08 (ACI 318-05) and ACI 318 D.6.1.2.

⁶Anchors are permitted to be used in structural sand-lightweight concrete in accordance with Section 4.1.11 of this report.

⁷Tabulated values for steel strength in shear are for seismic applications and based on test results in accordance with ACI 355.2, Section 9.6.

⁸Tabulated values for $V_{sa,deck}$ are for structural sand-lightweight concrete ($f'_{c,min} = 3,000$ psi) and additional lightweight concrete reduction factors need not be applied. In addition, evaluation for the concrete breakout capacity in accordance with ACI 318 D.6.2 and the prout capacity in accordance with Section D.6.3 are not required for anchors installed in the deck soffit (flute).

⁹Shear loads for anchors installed through steel deck into concrete may be applied in any direction.

* ¹⁰For the 2003 IBC f_{uta} replaces f_{ut} ; V_{sa} replaces V_s ; ℓ_e replaces ℓ ; and $V_{sa,seis}$ replaces V_{sa} .

¹¹The notation in brackets is for the 2006 IBC.

TABLE 5—EXAMPLE ALLOWABLE STRESS DESIGN VALUES FOR ILLUSTRATIVE PURPOSES^{1,2,3,4,5,6,7,8,9}

Anchor Diameter (inches)	Nominal Embedment Depth (inches)	Effective Embedment (inches)	Allowable Tension Load (pounds)
1/4	1 3/4	1.50	970
3/8	2 3/8	2.00	1,260
1/2	2 1/2	2.00	1,415
	3 3/4	3.25	2,425
5/8	3 3/8	2.75	2,405
	4 5/8	4.00	4,215
3/4	4	3.125	2,910
1	5-1/2	4.375	4,820

For SI: 1 inch = 25.4 mm, 1 lbf = 4.45 N.

¹Single anchor with static tension load only.

²Concrete determined to remain uncracked for the life of the anchorage.

³Load combinations are taken from ACI 318 Section 9.2 (no seismic loading).

⁴30% dead load and 70% live load, controlling load combination 1.2D + 1.6L.

⁵Calculation of weighted average for conversion factor $\alpha = 1.2(0.3) + 1.6(0.7) = 1.48$.

⁶ $f'_c = 2,500$ psi (normal weight concrete).

⁷ $C_{a1} = C_{a2} \geq C_{ac}$.

⁸ $h \geq h_{min}$.

⁹Values are for Condition B where supplementary reinforcement in accordance with ACI 318 D.4.4 is not provided.

Given: Calculate the factored strength design resistance, ϕN_n , and the allowable stress design value, $T_{allowable, ASD}$, for a 3/8-inch diameter Power-Stud+ SD1 expansion anchor assuming the given conditions in Table 5.		
Calculation in accordance with ACI 318-05 Appendix D and this report:	Code Ref.	Report Ref.
<p>Step 1. Calculate steel strength of a single anchor in tension:</p> $\phi N_{sa} = (0.75)(5,455) = 4,091 \text{ lbs.}$	D.5.1.2	Table 3
<p>Step 2. Calculate concrete breakout strength of a single anchor in tension:</p> $\phi N_{cb} = \phi \frac{A_{Nc}}{A_{Nc0}} \psi_{ed,N} \psi_{c,N} \psi_{ep,N} N_b$ $N_b = k_c \sqrt{f'_c} (h_{ef})^{1.5}$ $N_b = (24) \sqrt{2,500} (2.0)^{1.5} = 3,394 \text{ lbs.}$ $\phi N_{cb} = (0.65) \frac{(36.0)}{(36.0)} (1.0)(1.0)(1.0)(3,394) = 2,206 \text{ lbs.}$	D.5.2.1 D.5.2.2	Table 3 Table 3
<p>Step 3. Calculate pullout strength:</p> $\phi N_{pn} = \phi N_{p,uncr} \psi_{c,P} \left(\frac{f'_{c,act}}{2,500} \right)^{0.5}$ $\phi N_{pn} = (0.65)(2,865)(1.0)(1.0)^{0.5} = 1,862 \text{ lbs.}$	D.5.3.2	Table 3
<p>Step 4. Determine controlling factored resistance strength in tension:</p> $\phi N_n = \min \phi N_{sa}, \phi N_{cb}, \phi N_{pn} = \phi N_{pn} = 1,862 \text{ lbs.}$	D.4.1.1	
<p>Step 5. Calculate allowable stress design conversion factor for loading condition:</p> <p>Controlling load combination: 1.2D + 1.6L</p> $\alpha = 1.2(30\%) + 1.6(70\%) = 1.48$	9.2	
<p>Step 6. Calculate allowable stress design value:</p> $T_{allowable, ASD} = \frac{\phi N_n}{\alpha} = \frac{1,862}{1.48} = 1,258 \text{ lbs.}$		Sec. 4.2

FIGURE 5—EXAMPLE STRENGTH DESIGN CALCULATION INCLUDING ASD CONVERSION FOR ILLUSTRATIVE PURPOSES