

**ICC Evaluation Service, Inc.**  
[www.icc-es.org](http://www.icc-es.org)

**Business/Regional Office** ■ 5360 Workman Mill Road, Whittier, California 90601 ■ (562) 699-0543  
**Regional Office** ■ 900 Montclair Road, Suite A, Birmingham, Alabama 35213 ■ (205) 599-9800  
**Regional Office** ■ 4051 West Flossmoor Road, Country Club Hills, Illinois 60478 ■ (708) 799-2305

**DIVISION: 03—CONCRETE**  
**Section: 03151—Concrete Anchoring**

**REPORT HOLDER:**

**POWERS FASTENERS, INC.**  
2 POWERS SQUARE  
NEW ROCHELLE, NEW YORK 10801  
(914) 235-6300  
[www.powers.com](http://www.powers.com)  
[engineering@powers.com](mailto:engineering@powers.com)

**EVALUATION SUBJECT:**

**POWERS POWER-BOLT, POWER-STUD, STEEL DROPIN,  
HOLLOW-SET DROPIN AND SPIKE EXPANSION ANCHORS**

**ADDITIONAL LISTEES:**

**L.H. DOTTIE COMPANY**  
6131 SOUTH GARFIELD AVENUE  
COMMERCE, CALIFORNIA 90040  
PRODUCTS: DOTTIE WEDGE ANCHOR AND DOTTIE  
DROP-IN ANCHOR

**GRABBER**  
205 MASON CIRCLE  
CONCORD, CALIFORNIA 94520  
PRODUCTS: GRABBER WEDGE ANCHOR AND  
GRABBER DROP-IN ANCHOR

**1.0 EVALUATION SCOPE**

**Compliance with the following codes:**

- 2000 *International Building Code*® (IBC)
- 2000 *International Residential Code*® (IRC)
- 1997 *Uniform Building Code*™ (UBC)

**Properties evaluated:**

Structural

**2.0 USES**

The Powers Power-Bolt, Power-Stud, Steel Dropin, Hollow-Set Dropin and Spike expansion anchors are used for anchoring building components and structural connections in normal-weight concrete and structural lightweight concrete to resist dead, live, earthquake and wind loads.

The anchors are alternatives to the cast-in-place anchors described in Section 1912 of the IBC and Section 1923.1 of

the UBC. The anchors may also be used where an engineered design is submitted in accordance with Section R301.12 of the IRC.

**3.0 DESCRIPTION**

**3.1 Materials:**

**3.1.1 Power-Bolt Anchor:** The Power-Bolt anchor is a heavy-duty, sleeve-type anchor available with either a finished hex head or a flat head for use in normal-weight and structural lightweight concrete. The carbon steel hex head and flat head styles are assembled using a Grade 5 bolt complying with ASTM A 449, a hardened washer complying with ANSI B18.22.1-1965 (no washer on flathead style), a nylon compression ring, a precision-stamped expansion sleeve manufactured from AISI 1010-1020 steel (an extender sleeve is included on the longer lengths), and a partially slotted cone manufactured from AISI 12L14 steel. The carbon steel version of the anchor is zinc-plated with a supplemental chromate finish in accordance with ASTM B 633. The mechanically galvanized version is plated in accordance with ASTM B 695, Class 65.

The Type 304 stainless steel hex head style is assembled using a Type 18-8 (300 series) hex head bolt complying with ASTM F 593, Alloy Group 1; a Type 18-8 washer; a nylon compression ring; a precision-stamped expansion sleeve manufactured from Type 304 stainless steel (an extender sleeve is also included on the longer lengths); and a partially slotted cone manufactured from Type 303 stainless steel.

As the anchor is driven into a predrilled hole, the slotted, oversized, annular anti-vibration ring at the bottom of the cone reduces in size until it mates with the hole to prevent the anchor from spinning in the hole while it is tightened. As the anchor is tightened, the nylon compression ring will, if necessary, compress to ensure that the material being fastened is tightly secured against the face of the concrete.

Expansion occurs at two levels within the drilled hole. The cone is pulled into the large triple-tined expansion sleeve, developing a midlevel load-bearing capacity over a large surface area. Further turning of the bolt causes the threaded portion of the bolt to advance into the threads at the compressed end of the cone. Allowable tension and shear values are noted in Tables 2 and 3.

**3.1.2 Power-Stud Anchor:** The Power-Stud anchor is a one-piece steel expansion anchor with dual interlocking steel-expansion wedges designed for use in normal-weight and structural lightweight concrete. It is available in threaded, tie-wire, rod hanger, and rod coupling styles. Zinc-plated carbon steel, mechanically galvanized carbon steel, and stainless steel versions are available.

\*Revised January 2006

The carbon steel anchor bodies are cold-formed from AISI 1018 carbon steel for the  $\frac{1}{4}$ -inch (6.4 mm) through  $\frac{3}{4}$ -inch (19.1 mm) diameters with lengths of 7 inches (178 mm) or less. For the  $\frac{5}{8}$ -inch (15.9 mm) or  $\frac{3}{4}$ -inch (19.1 mm) diameters with lengths longer than 7 inches (178 mm), and for the  $\frac{7}{8}$ -inch (22 mm) and larger diameters, the anchor body is machined from AISI 12L14 steel. The interlocking wedges are formed from AISI 1010 carbon steel. The nuts are commercial grade steel complying with ASTM A 563, Grade A, and the washers are AISI 1010 carbon steel. The anchor is plated with commercial zinc with a supplemental chromate finish in accordance with ASTM B 633. The mechanically galvanized version is plated in accordance with ASTM B 695, Class 65.

For the Type 304 stainless steel version, the anchor body for the  $\frac{1}{4}$ -inch (6.4 mm) through  $\frac{3}{4}$ -inch (19.1 mm) diameters [with lengths of 7 inches (178 mm) or less] is manufactured from AISI Type 304, Cu (302 HQ), stainless steel. The anchor bodies for the  $\frac{5}{8}$ -inch (15.9 mm) or  $\frac{3}{4}$ -inch (19.1 mm) diameters with lengths greater than 7 inches (178 mm), and the  $\frac{7}{8}$ -inch (22 mm) or larger diameters, are machined from ASTM F 593, Type 303/304, stainless steel. The interlocking clips are Type 304 stainless steel. The nuts and washers are commercial grade, manufactured from Type 18-8 (300 Series) stainless steel. On the Type 316 stainless steel version, the anchor body is manufactured from AISI Type 316 stainless steel meeting the requirements of ASTM A 193. The interlocking clips are Type 304 or Type 316 stainless steel. The nuts and washers are commercial grade, manufactured from AISI Type 316 stainless steel.

The anchor body is threaded or stamped with a spade head on the upper end, and has a tapered expansion section on the working end, on which a set of interlocking wedges is mounted. Each wedge is fastened to the reduced diameter of the stud by interlocking tabs. As the anchor is tightened, the wedge mechanism compresses against the wall of the anchor hole. Allowable tension and shear loads are noted in Tables 5 and 6.

**3.1.3 Steel Dropin Anchor:** The Steel Dropin anchor is an internally threaded expansion anchor complete with an internal expander plug designed for use in normal-weight and structural lightweight concrete. The Steel Dropin anchor is supplied in carbon steel, coil thread, Type 304 stainless steel, and Type 316 stainless steel versions.

In the carbon steel and coil thread versions, the anchor body is manufactured from AISI 12L14 carbon steel, and the expansion cone is formed from AISI 1018 carbon steel. The anchors are plated with commercial zinc with a supplemental chromate finish in accordance with ASTM B 633. The mechanically galvanized version is plated in accordance with ASTM B 695, Class 65.

For the Type 304 stainless steel version, the anchor body is manufactured from ASTM F 593, Type 303, stainless steel, and the expansion cone is formed from ASTM F 593, Type 304, stainless steel. On the Type 316 version, the anchor body and the expansion cone are manufactured from ASTM F 593, Type 316, stainless steel.

As the anchor is expanded with a setting tool, the preassembled internal expander plug flares the anchor shell radially, compressing against the wall of the anchor hole. Allowable tension and shear loads are noted in Tables 8 and 9.

**3.1.4 Hollow-Set Dropin Anchor:** The Hollow Set Dropin anchor is designed with a slotted, tapered expansion sleeve and an internally threaded expansion cone for shallow embedment applications in normal-weight concrete materials, including precast plank.

The expansion sleeve is formed from Zamac alloy, and the expansion cone is formed from either AISI 12L14 carbon steel, which is zinc-plated in accordance with ASTM B 633, or Type 304 stainless steel. The mechanically galvanized version is plated in accordance with ASTM B 695, Class 65.

Allowable tension and shear loads are noted in Table 11.

**3.1.5 Spike Anchor:** The Spike anchor is a one-piece, pre-expanded steel anchor for use in normal-weight and structural lightweight concrete. It is available in mushroom head, flat head, pipe (rod coupler) head, tie-wire, and forming head (duplex) styles. The carbon steel anchors are manufactured from AISI 1038-1040 carbon steel and meet the requirements of Grade 8.2 steel. The anchors are zinc-plated with a supplemental chromate finish in accordance with ASTM B 633, SC1, Type III. The stainless steel anchors are manufactured from AISI Type 316 stainless steel meeting the requirements of ASTM A 193. The mechanically galvanized version is plated in accordance with ASTM B 695, Class 65.

As the anchor is driven into a predrilled hole, the anchor body is automatically activated. The expansion mechanism creates a residual spring-type compression force into the base material at three levels at the bottom of the hole. There is no need to torque or tighten the anchor once it is set. Allowable tension and shear loads are noted in Tables 13 and 14.

## 4.0 DESIGN AND INSTALLATION

### 4.1 Design:

Allowable loads for the anchors are in Tables 2, 3, 5, 6, 8, 9, 11, 13 and 14. Allowable loads for the Power-Bolt, Power-Stud, Steel Dropin, Hollow-Set and Spike anchors subjected to combined shear and tension forces are determined using the following equation:

$$(P_s / P_t) + (V_s / V_t) \leq 1$$

where:

$P_s$  = Applied service tension load.

$P_t$  = Allowable service tension load.

$V_s$  = Applied service shear load.

$V_t$  = Allowable service shear load.

The Power-Bolt, Power-Stud, Steel Dropin, Hollow-Set Dropin and Spike Anchors are recognized to resist short-term loading due to seismic and wind forces. For anchors installed in normal-weight concrete (Tables 2, 5, 8, 11 and 13) and the Power-Stud anchors installed in structural lightweight concrete (Table 6) when using the basic load combinations in accordance with IBC Section 1605.3.1.1 or UBC Section 1612.3.1, the allowable loads are not permitted to be increased for wind or earthquake loading. When using the alternative basic load combinations in IBC Section 1605.3.2 or UBC Section 1612.3.2 that include wind or seismic loads, the allowable shear and tension loads for anchors installed in normal-weight concrete and the Power-Stud anchors installed in structural lightweight concrete are permitted to be increased by  $33\frac{1}{3}$  percent. Alternatively, the basic load combinations may be reduced by a factor of 0.75 when using IBC Section 1605.3.2.

Use of the Power-Bolt, Steel Dropin, Hollow-Set Dropin and Spike anchors to resist seismic loads in structural lightweight concrete (Tables 3, 9 and 14) is not permitted. The allowable loads or load combinations for the anchors shall not be adjusted for anchors subject to wind loads when installed in structural lightweight concrete.

## 4.2 Installation:

**4.2.1 Power-Bolt Anchor:** Embedment, spacing, edge distance, and concrete requirements are shown in Tables 2, 3 and 4. Anchor holes must be predrilled in concrete using a bit complying with ANSI B212.15-1994. The anchors must be installed in holes having a diameter equal to the nominal anchor diameter, drilled to a depth allowing the required embedment. Dust and debris must be removed from the holes by means of a blow-out bulb or a jet of compressed air. The Power-Bolt must be inserted through the material being fastened; the anchor must be driven into the hole until it is flush with the work surface at the desired embedment depth, which under no circumstances is permitted to be less than the minimum embedment. The bolt in the anchor assembly must be tightened until the minimum installation torque listed in Tables 2 and 3 is achieved.

**4.2.2 Power-Stud Anchor:** Embedment, spacing, edge distance, and concrete requirements are shown in Tables 5, 6 and 7. Anchor holes must be predrilled in concrete using a bit complying with ANSI B212.15-1994. The anchors must be installed in holes having a diameter equal to the nominal anchor diameter, drilled to a depth allowing the required embedment. Dust and debris must be removed from the holes by means of a blow-out bulb or a jet of compressed air. The anchor must be driven into the hole until it is at the desired embedment depth, which under no circumstances is permitted to be less than the minimum embedment. The anchor is set by tightening the nut against the washer until the minimum installation torque listed in Tables 5 and 6 is achieved.

**4.2.3 Steel Dropin Anchor:** Embedment, spacing, edge distance, and concrete requirements are shown in Tables 8, 9 and 10. Anchor holes must be predrilled in concrete using a bit complying with ANSI B212.15-1994. The anchors must be installed in holes having the diameters and depths listed in Tables 8 and 9. Dust and debris must be removed from the holes by means of a blow-out bulb or a jet of compressed air. The anchor is inserted into the hole until it is flush with the work surface at the desired embedment depth, which under no circumstances is permitted to be less than the minimum embedment. A matching setting tool is used to properly expand the anchor.

**4.2.4 Hollow-Set Dropin Anchor:** Embedment, spacing, edge distance, and concrete requirements are shown in Tables 11 and 12. Anchor holes must be predrilled in concrete using a bit complying with ANSI B212.15-1994. The anchors must be installed in holes having the diameters and depths listed in Table 11. Dust and debris must be removed from the hole by means of a blow-out bulb or a jet of compressed air. The anchor is inserted into the hole until it is flush with the work surface at the desired embedment depth, which under no circumstances is permitted to be less than the minimum embedment. A matching hollow or solid setting tool is supplied to properly expand the anchor.

**4.2.5 Spike Anchor:** Embedment, spacing, edge distance, and concrete requirements for the Spike anchor are shown in Tables 13, 14 and 15. Anchor holes must be predrilled in concrete using a bit complying with ANSI B212.15-1994. The anchors must be installed in holes having a diameter equal to the nominal anchor diameter, drilled to a depth allowing the required embedment plus  $\frac{1}{2}$  inch (12.7 mm). Dust and debris must be removed from the hole using a blowout bulb or a jet of compressed air. Except for the pipe and tie-wire head styles, the anchor must be inserted through the material being fastened. The anchor must be driven into the hole until it is flush with the work surface at the desired embedment depth. The anchor must be installed in accordance to the manufacturer's installation instructions.

## 4.3 Installation with Special Inspection:

When design loads require special inspection during anchor installation, compliance with Section 1704 of the IBC and Section 1701 of the UBC is necessary. The inspector's duties include verification of anchor type and dimensions; concrete type and compressive strength; predrilled hole dimensions and cleanliness; drill bit compliance with ANSI B212.15-994; anchor spacings, edge distances and embedment; and anchor installation in accordance with the manufacturer's published installation instructions and this report.

## 5.0 CONDITIONS OF USE

The Powers Power-Bolt, Power-Stud, Steel Dropin, Hollow-Set Dropin and Spike Expansion Anchors described in this report comply with, or are suitable alternatives to what is specified in, those codes listed in Section 1.0 of this report, subject to the following conditions:

- 5.1 Anchor sizes, dimensions, and installation are as set forth in this report.
- 5.2 Allowable tension and shear values comply with this report.
- 5.3 Calculations justifying that the applied loads comply with this report are submitted to the building official for approval.
- 5.4 Special inspection is provided as set forth in Section 4.3 of this report.
- 5.5 Since an ICC-ES acceptance criteria from evaluating data to determine the performance of expansion anchors subjected to fatigue or shock loading is unavailable at this time, the use of these anchors under these conditions is beyond the scope of this report.
- 5.6 Anchors are not permitted for use in conjunction with fire-resistive construction. Exceptions would be:
  - Anchors resist wind or seismic loading only.
  - For other than wind or seismic loading, special consideration is given to fire exposure conditions.
- 5.7 Since an ICC-ES acceptance criteria for evaluating the performance of anchors in cracked concrete is unavailable at this time, the use of anchors is limited to installation in uncracked concrete. Cracking occurs when  $f_t > f_r$  due to service loads or deformations.
- 5.8 The design of the Power-Bolt, Power-Stud, Steel Dropin, Hollow-Set Dropin and Spike anchors to resist short-term loading due to seismic or wind forces shall comply with Section 4.1 of this report.
- 5.9 Anchors are limited to interior use, except that installation in severe, moderate, or negligible exterior weathering locations, in accordance with Figure 21-1-1 of UBC Standard 21-1 or Figure 1 of ASTM C 62-97a (IBC or IRC), is permitted when stainless steel or mechanically galvanized (in accordance with ASTM B 695, Class 65) anchors are installed.
- 5.10 The Power-Bolt and Hollow-Set Dropin anchors are manufactured by Powers Fasteners, Inc., at its facility in New Rochelle, New York. The Power-Stud and Spike anchors are manufactured by Powers Fasteners, Inc., at its facility in Hudson, Michigan. The Steel Dropin anchor is distributed by Powers Fasteners, Inc., with manufacturing locations documented in a quality control manual. Manufacturing processes of all anchors and quality control procedures for all anchors are subject to quality control inspections by CEL Consulting (AA-639).

## 6.0 EVIDENCE SUBMITTED

6.1 Data complying with the ICC-ES Acceptance Criteria for Expansion Anchors in Concrete and Masonry Elements (AC01), dated October 2004.

6.2 A quality control manual.

## 7.0 IDENTIFICATION

The anchors are identified in the field by dimensional characteristics and packaging. The packaging label bears the

name and address of Powers Fasteners, Inc., or one of the additional listees noted in this report, the size and type of anchor, and the evaluation report number (ESR-1532 or ER-5225). A length letter code is stamped on the end of the Power-Bolt, Power-Stud and Spike anchors. See the length identification system in Table 16. Products distributed by the additional listees noted at the beginning of this report are as noted in Table 17.

TABLE 1—APPLICATION DESCRIPTIONS

ANCHOR	BASE MATERIAL	SPECIFICATION DATA	LOAD DATA
Power-Bolt	Normal-weight concrete	Section 3.1.1 and Tables 2 & 4	Table 2
	Structural lightweight concrete	Section 3.1.1 and Tables 3 & 4	Table 3
Power-Stud	Normal-weight concrete	Section 3.1.2 and Tables 5 & 7	Table 5
	Structural lightweight concrete	Section 3.1.2 and Tables 6 & 7	Table 6
Steel Dropin	Normal-weight concrete	Section 3.1.3 and Tables 8 & 10	Table 8
	Structural lightweight concrete	Section 3.1.3 and Tables 9 & 10	Table 9
Hollow-Set Dropin	Normal-weight concrete	Section 3.1.4 and Tables 11 & 12	Table 11
Spike	Normal-weight concrete	Section 3.1.5 and Tables 13 & 15	Table 13
	Structural lightweight concrete	Section 3.1.5 and Tables 14 & 15	Table 14

TABLE 2—POWER-BOLT ANCHOR ALLOWABLE TENSION AND SHEAR LOAD VALUES WHEN INSTALLED IN NORMAL-WEIGHT CONCRETE<sup>1,2,4,5,6</sup> (pounds)

ANCHOR DIAMETER, <i>d</i> (inch)	EMBED-MENT DEPTH, <i>h<sub>v</sub></i> (inches)	INSTALLATION TORQUE GUIDE VALUES (ft.-lbs.)		<i>f'<sub>c</sub></i> = 2,000 psi			<i>f'<sub>c</sub></i> = 4,000 psi			<i>f'<sub>c</sub></i> = 6,000 psi				
				Carbon	Stainless	Tension		Shear	Tension		Shear	Tension		Shear
						With Sp. Insp. <sup>3</sup>	Without Sp. Insp.		With Sp. Insp. <sup>3</sup>	Without Sp. Insp.		With Sp. Insp. <sup>3</sup>	Without Sp. Insp.	
				1/4	1 1/4	3 - 4	3 - 4	250	125	515	250	125	530	250
1 3/4	3 - 4	3 - 4	270		135	515	265	135	635	300	150	635		
2 1/2	3 - 4	3 - 4	270		135	515	280	140	845	380	190	845		
3/8	2	25 - 35	15 - 20	780	390	995	1,145	575	1,605	1,480	740	1,605		
	2 1/2	25 - 35	15 - 20	840	420	995	1,215	605	1,790	1,665	835	1,790		
	3 1/2	25 - 35	15 - 20	1,100	550	995	1,500	750	2,165	1,790	895	2,165		
1/2	2 1/2	45 - 60	25 - 35	1,075	540	1,710	1,465	730	2,055	1,830	915	2,055		
	3 1/2	45 - 60	25 - 35	1,205	605	1,710	2,050	1,025	2,465	2,470	1,235	2,465		
	5	45 - 60	25 - 35	1,255	625	1,710	2,220	1,110	3,080	2,735	1,365	3,080		
5/8	2 3/4	80 - 100	45 - 60	820	410	1,995	1,925	965	2,995	2,125	1,060	2,995		
	4	80 - 100	45 - 60	1,295	640	1,995	2,190	1,095	3,640	3,275	1,640	3,640		
	6	80 - 100	45 - 60	1,295	640	1,995	2,735	1,365	4,670	3,390	1,695	4,670		
3/4	3	95 - 120	70 - 90	1,415	710	3,095	2,045	1,020	4,025	2,695	1,350	4,025		
	4 1/2	95 - 120	70 - 90	1,450	725	3,095	2,715	1,360	4,955	3,465	1,735	4,955		
	7	95 - 120	70 - 90	1,495	745	3,095	3,300	1,650	6,510	4,850	2,425	6,510		

For SI: 1 inch = 25.4 mm, 1 psi = 6.89 kPa, 1 lbf = 4.45 N, 1 foot-pound = 1.36 N-m.

<sup>1</sup>The tabulated shear and tension values are for anchors installed in normal-weight concrete that has reached the minimum designated ultimate compressive strength at the time of installation. Linear interpolation may be used for concrete strengths and embedment depths between those listed.

<sup>2</sup>The tabulated values are for anchors installed with spacing and edge distance in accordance with Table 4.

<sup>3</sup>These tension values are applicable only when the anchors are installed with special inspection as set forth in Section 4.3.

<sup>4</sup>Refer to Section 4.1 for design requirements concerning anchors resisting earthquake and wind loads.

<sup>5</sup>The allowable loads for anchors installed with special inspection are calculated using an applied safety factor of 4.0.

<sup>6</sup>Concrete slab thickness must be at least 1 1/2 *h<sub>v</sub>*.

**TABLE 3—POWER-BOLT ANCHOR ALLOWABLE TENSION AND SHEAR LOAD VALUES WHEN INSTALLED IN STRUCTURAL LIGHTWEIGHT CONCRETE<sup>1,5,6</sup> (pounds)**

ANCHOR INSTALLED IN LIGHTWEIGHT CONCRETE <sup>3,7</sup>									
Anchor Diameter, <i>d</i> (inch)	Embedment Depth, <i>h<sub>v</sub></i> (inches)	Installation Torque Guide Values (ft.-lbs.)	Tension						Shear <i>f'<sub>c</sub></i> ≥ 3,000 psi
			With Special Inspection <sup>2</sup>			Without Special Inspection			
			Concrete Strength, <i>f'<sub>c</sub></i>			Concrete Strength, <i>f'<sub>c</sub></i>			
			3,000 psi	4,000 psi	5,000 psi	3,000 psi	4,000 psi	5,000 psi	
1/4	1 1/4	3 - 4	250	290	330	125	145	165	380
3/8	2	25 - 35	540	675	810	270	335	405	695
1/2	2 1/2	45 - 60	920	1,075	1,230	460	535	615	1,155
5/8	2 3/4	80 - 100	780	1,045	1,310	390	520	655	1,710
3/4	3	95 - 120	1,400	1,685	1,970	700	840	985	2,190
ANCHOR INSTALLED THROUGH MIN. 20 GAGE METAL DECK INTO LIGHTWEIGHT CONCRETE ( <i>f'<sub>c</sub></i> ≥ 3,000 psi) <sup>4,8</sup>									
Anchor Diameter, <i>d</i> (inch)	Embedment Depth, <i>h<sub>v</sub></i> (inches)	Installation Torque Guide Values (ft.-lbs.)	Minimum 4 1/2" Wide Deck			Minimum 1 1/2" Wide Deck			
			Tension		Shear	Tension		Shear	
			With Sp. Insp. <sup>2</sup>	Without Sp. Insp.		With Sp. Insp. <sup>2</sup>	Without Sp. Insp.		
1/4	1 1/4	3 - 4	230	115	590	180	90	590	
3/8	2	25 - 35	460	230	685	180	90	685	
1/2	2 1/2	45 - 60	500	250	1,100	410	205	685	
5/8	2 3/4	80 - 100	500	250	1,110	—	—	—	
3/4	3	95 - 120	1,240	620	1,120	—	—	—	

For SI: 1 inch = 25.4 mm, 1 psi = 6.89 kPa, 1 lbf = 4.45 N, 1 foot-pound = 1.36 N-m.

<sup>1</sup>Tabulated load values are for anchors installed in sand-lightweight concrete that has reached the minimum designated ultimate compressive strength at the time of installation. Linear interpolation may be used for concrete strengths between those listed.

<sup>2</sup>These tension load values are applicable only when the anchors are installed with special inspection as set forth in Section 4.3.

<sup>3</sup>The tabulated load values are for anchors installed with spacing and edge distance in accordance with Table 4.

<sup>4</sup>The tabulated load values are for anchors installed in the center of the flute with spacing distance in accordance with Table 4. Linear interpolation may be used for flute edge distances between those listed. Flute edge distance equals one-half the minimum deck width.

<sup>5</sup>Refer to Section 4.1 for design requirements concerning anchors resisting earthquake and wind loads.

<sup>6</sup>The allowable loads for anchors installed with special inspection are calculated using an applied safety factor of 4.0.

<sup>7</sup>Concrete slab thickness must be at least 1 1/2 *h<sub>v</sub>*.

<sup>8</sup>Anchors are permitted to be installed in the lower or upper flute of the metal deck provided the installation procedures are maintained. See Figure 1.

**TABLE 4—POWER-BOLT ANCHOR REDUCTION FACTORS FOR SPACING AND EDGE DISTANCE IN NORMAL-WEIGHT AND STRUCTURAL LIGHTWEIGHT CONCRETE<sup>1</sup>**

ANCHOR INSTALLED IN NORMAL-WEIGHT CONCRETE					
Anchor Dimension	Load Type	Critical Distance (Full Anchor Capacity)	Critical Load Factor	Minimum Distance (Reduced Capacity)	Minimum Load Factor
Spacing ( <i>s</i> )	Tension and shear	<i>s<sub>cr</sub></i> = 4.0 <i>h<sub>v</sub></i>	<i>F<sub>N</sub></i> = <i>F<sub>V</sub></i> = 1.0	<i>s<sub>min</sub></i> = 2.0 <i>h<sub>v</sub></i>	<i>F<sub>N</sub></i> = <i>F<sub>V</sub></i> = 0.50
Edge distance ( <i>c</i> )	Tension	<i>c<sub>cr</sub></i> = 12 <i>d</i>	<i>F<sub>N</sub></i> = 1.0	<i>c<sub>min</sub></i> = 5 <i>d</i>	<i>F<sub>N</sub></i> = 0.70
	Shear	<i>c<sub>cr</sub></i> = 12 <i>d</i>	<i>F<sub>V</sub></i> = 1.0	<i>c<sub>min</sub></i> = 5 <i>d</i>	<i>F<sub>V</sub></i> = 0.35
ANCHOR INSTALLED IN LIGHTWEIGHT CONCRETE					
Anchor Dimension	Load Type	Critical Distance (Full Anchor Capacity)	Critical Load Factor	Minimum Distance (Reduced Capacity)	Minimum Load Factor
Spacing ( <i>s</i> )	Tension and shear	<i>s<sub>cr</sub></i> = 4.0 <i>h<sub>v</sub></i>	<i>F<sub>N</sub></i> = <i>F<sub>V</sub></i> = 1.0	<i>s<sub>min</sub></i> = 2.0 <i>h<sub>v</sub></i>	<i>F<sub>N</sub></i> = <i>F<sub>V</sub></i> = 0.50
Edge distance ( <i>c</i> )	Tension	<i>c<sub>cr</sub></i> = 12 <i>d</i>	<i>F<sub>N</sub></i> = 1.0	<i>c<sub>min</sub></i> = 5 <i>d</i>	<i>F<sub>N</sub></i> = 0.80
	Shear	<i>c<sub>cr</sub></i> = 12 <i>d</i>	<i>F<sub>V</sub></i> = 1.0	<i>c<sub>min</sub></i> = 5 <i>d</i>	<i>F<sub>V</sub></i> = 0.40

*h<sub>v</sub>* = Embedment depth. When adjacent anchors are at different embedments, use largest value for *h<sub>v</sub>*.  
*d* = Anchor diameter. When adjacent anchors are different sizes, use largest value for *d*.  
*s* = The measure between anchors, centerline to centerline distance.  
*s<sub>cr</sub>* = The minimum anchor spacing distance at which the anchor load capacity is not influenced by adjacent anchors.  
*s<sub>min</sub>* = The minimum anchor spacing distance at which the anchors are tested for recognition.  
*c* = The measure between the anchor centerline and the free edge of the base material.  
*c<sub>cr</sub>* = The minimum anchor edge distance at which the anchor load capacity is not influenced by the edge of the base material.  
*c<sub>min</sub>* = The minimum edge distance at which the anchors are tested for recognition.  
*F<sub>N</sub>* = Reduction factor applied to tension load capacities when spacing and edge distances are at minimum distances.  
*F<sub>V</sub>* = Reduction factor applied to shear load capacities when spacing and edge distances are at minimum distances.

<sup>1</sup>Load values in the tables are multiplied by the reduction factors when spacing and edge distances are less than critical distances. Linear interpolation is allowed for spacing and edge distances that fall between critical and minimum distances. When a group of anchors is affected by both reduced spacing and reduced edge distance, the spacing and edge distance reduction factors must be combined (multiplied).

**TABLE 5—POWER-STUD ANCHOR ALLOWABLE TENSION AND SHEAR LOAD VALUES  
WHEN INSTALLED IN NORMAL-WEIGHT CONCRETE<sup>1,2,4,5,6</sup> (pounds)**

ANCHOR DIAMETER, <i>d</i> (inches)	EMBEDMENT DEPTH, <i>h<sub>v</sub></i> (inches)	INSTALLATION TORQUE GUIDE VALUES (ft.-lbs.)	<i>f'<sub>c</sub></i> = 2,000 psi		<i>f'<sub>c</sub></i> = 4,000 psi		<i>f'<sub>c</sub></i> = 6,000 psi				
			Tension		Shear	Tension		Shear	Tension		
			With Sp. Insp. <sup>3</sup>	Without Sp. Insp.		With Sp. Insp. <sup>3</sup>	Without Sp. Insp.		With Sp. Insp. <sup>3</sup>	Without Sp. Insp.	
1/4	1 1/8	8	310	155	395	360	180	405	435	215	405
	2	8	475	235	395	520	260	405	525	260	405
3/8	1 5/8	28	480	240	890	760	380	940	760	380	940
	3	28	1,025	510	995	1,505	755	940	1,505	755	940
1/2	2 1/4	60	860	430	1,635	1,390	695	1,700	1,635	820	1,700
	4	60	1,425	710	1,635	2,040	1,020	1,700	2,300	1,150	1,700
5/8	2 3/4	90	1,560	785	2,320	2,075	1,040	2,975	2,465	1,235	2,975
	5	90	2,660	1,330	2,320	3,125	1,565	2,975	4,100	2,050	2,975
3/4	3 3/8	175	1,855	930	3,095	2,185	1,095	3,765	3,135	1,565	3,765
	6	175	1,860	930	3,095	3,115	1,560	3,765	5,045	2,520	3,765
7/8	3 7/8	250	1,475	740	4,490	3,075	1,540	6,040	4,325	2,160	6,040
	7	250	1,805	900	4,490	5,110	2,555	6,040	7,795	3,900	6,040
1	4 1/2	300	2,185	1,095	6,605	3,455	1,730	7,775	5,305	2,560	7,775
	8	300	5,590	2,795	6,605	6,760	3,380	7,775	11,055	5,525	7,775
1 1/4	5 1/2	450	3,820	1,910	10,205	6,745	3,370	10,205	9,230	4,615	10,205
	10	450	6,510	3,255	10,205	13,070	6,535	10,205	15,170	7,585	10,205

For SI: 1 inch = 25.4 mm, 1 psi = 6.89 kPa, 1 lbf = 4.45 N, 1 foot-pound = 1.36 N-m.

<sup>1</sup>The tabulated shear and tension values are for anchors installed in normal-weight concrete that has reached the minimum designated ultimate compressive strength at the time of installation. Linear interpolation may be used for concrete strengths and embedment depths between those listed.

<sup>2</sup>The tabulated values are for anchors installed with spacing and edge distance in accordance with Table 7.

<sup>3</sup>These tension values are applicable only when the anchors are installed with special inspection as set forth in Section 4.3.

<sup>4</sup>Refer to Section 4.1 for design requirements concerning anchors resisting earthquake and wind loads.

<sup>5</sup>The allowable loads for anchors installed with special inspection are calculated using an applied safety factor of 4.0.

<sup>6</sup>Concrete slab thickness must be at least 1 1/2 *h<sub>v</sub>*. Compliance with Section 1907.7 of the UBC must be provided.

**TABLE 6—POWER-STUD ANCHOR ALLOWABLE TENSION AND SHEAR LOAD VALUES  
WHEN INSTALLED IN STRUCTURAL LIGHTWEIGHT CONCRETE<sup>1,5,6</sup> (pounds)**

ANCHOR INSTALLED IN LIGHTWEIGHT CONCRETE <sup>3,7</sup>									
Anchor Diameter, <i>d</i> (inch)	Embedment Depth, <i>h<sub>v</sub></i> (inches)	Installation Torque Guide Values (ft.-lbs.)	Tension						Shear <i>f'<sub>c</sub></i> ≥ 3,000 psi
			With Special Inspection <sup>2</sup>			Without Special Inspection			
			Concrete Strength, <i>f'<sub>c</sub></i>			Concrete Strength, <i>f'<sub>c</sub></i>			
			3,000 psi	4,000 psi	5,000 psi	3,000 psi	4,000 psi	5,000 psi	
1/4	1 1/8	4	180	240	300	90	120	150	180
3/8	1 5/8	20	400	485	575	200	240	285	460
	3	20	—	715	—	—	355	—	460
1/2	2 1/4	30	705	795	890	350	395	445	1,260
	3	30	—	1,005	—	—	500	—	1,260
	5	30	—	1,050	—	—	525	—	1,260
5/8	2 3/4	65	1,095	1,245	1,395	545	620	695	1,735
	3 1/2	65	—	1,210	—	—	605	—	1,735
	5	65	—	1,730	—	—	865	—	1,735
3/4	3 3/8	90	1,265	1,400	1,535	630	695	765	2,470
	4	90	—	2,060	—	—	1,030	—	2,470
	5	90	—	2,325	—	—	1,160	—	2,470
ANCHOR INSTALLED THROUGH MIN. 20 GAGE METAL DECK INTO LIGHTWEIGHT CONCRETE ( <i>f'<sub>c</sub></i> ≥ 3,000 psi) <sup>4,8</sup>									
Anchor Diameter, <i>d</i> (inch)	Embedment Depth, <i>h<sub>v</sub></i> (inches)	Installation Torque Guide Values (ft.-lbs.)	Minimum 4 1/2" Wide Deck			Minimum 1 1/2" Wide Deck			
			Tension		Shear	Tension		Shear	
			With Sp. Insp. <sup>2</sup>	Without Sp. Insp.		With Sp. Insp. <sup>2</sup>	Without Sp. Insp.		
1/4	1 1/8	4	220	110	460	220	110	460	
3/8	1 5/8	20	380	190	700	220	110	700	
	3	20	1,120	560	960	220	110	700	
1/2	2 1/4	30	800	400	1,195	350	175	700	
	3	30	1,140	570	1,490	350	175	700	
	4	30	1,590	795	1,885	350	175	700	
5/8	2 3/4	65	800	400	1,195	—	—	—	
	3 1/2	65	1,385	690	1,790	—	—	—	
	5	65	2,300	1,150	2,735	—	—	—	
3/4	3 3/8	90	685	340	1,750	—	—	—	

For SI: 1 inch = 25.4 mm, 1 psi = 6.89 kPa, 1 lbf = 4.48 N.

<sup>1</sup>Tabulated load values are for anchors installed in structural lightweight concrete that has reached the minimum designated ultimate compressive strength at the time of installation. Linear interpolation may be used for concrete strengths and embedment depths between those listed.

<sup>2</sup>These tension load values are applicable only when the anchors are installed with special inspection as set forth in Section 4.3.

<sup>3</sup>The tabulated load values are for anchors installed with spacing and edge distance in accordance with Table 7.

<sup>4</sup>The tabulated load values are for anchors installed in the center of the flute with spacing distance in accordance with Table 7. Linear interpolation may be used for flute edge distances between those listed. Flute edge distance equals one-half the minimum deck width.

<sup>5</sup>Refer to Section 4.1 for design requirements concerning anchors resisting earthquake and wind loads.

<sup>6</sup>The allowable loads for anchors installed with special inspection are calculated using an applied safety factor of 4.0.

<sup>7</sup>Concrete slab thickness must be at least 1 1/2 *h<sub>v</sub>*.

<sup>8</sup>Anchors are permitted to be installed in the lower or upper flute of the metal deck provided the installation procedures are maintained. See Figure 1.

**TABLE 7—POWER-STUD ANCHOR REDUCTION FACTORS FOR SPACING AND EDGE DISTANCE  
IN NORMAL-WEIGHT AND STRUCTURAL LIGHTWEIGHT CONCRETE<sup>1,2</sup>**

ANCHOR INSTALLED IN NORMAL-WEIGHT CONCRETE					
Anchor Dimension	Load Type	Critical Distance (Full Anchor Capacity)	Critical Load Factor	Minimum Distance (Reduced Capacity)	Minimum Load Factor
Spacing (s)	Tension and shear	$s_{cr} = 4.0h_v$	$F_N = F_v = 1.0$	$s_{min} = 2.0h_v$	$F_N = F_v = 0.50$
Edge distance (c)	Tension	$c_{cr} = 12d$	$F_N = 1.0$	$c_{min} = 5d$	$F_N = 0.75$
	Shear	$c_{cr} = 12d$	$F_v = 1.0$	$c_{min} = 5d$	$F_v = 0.35$
ANCHOR INSTALLED IN LIGHTWEIGHT CONCRETE					
Anchor Dimension	Load Type	Critical Distance (Full Anchor Capacity)	Critical Load Factor	Minimum Distance (Reduced Capacity)	Minimum Load Factor
Spacing (s)	Tension and shear	$s_{cr} = 4.0h_v$	$F_N = F_v = 1.0$	$s_{min} = 2.0h_v$	$F_N = F_v = 0.50$
Edge distance (c)	Tension	$c_{cr} = 12d$	$F_N = 1.0$	$c_{min} = 5d$	$F_N = 0.95$
	Shear	$c_{cr} = 12d$	$F_v = 1.0$	$c_{min} = 5d$	$F_v = 0.30$

<sup>1</sup>Load values in the tables are multiplied by the reduction factors when spacing and edge distances are less than critical distances. Linear interpolation is allowed for spacing and edge distances that fall between critical and minimum distances. When a group of anchors is affected by both reduced spacing and reduced edge distance, the spacing and edge distance reduction factors must be combined (multiplied).

<sup>2</sup>All notations used in this table are defined in Table 4.

**TABLE 8—STEEL DROPIN ANCHOR ALLOWABLE TENSION AND SHEAR LOAD VALUES  
WHEN INSTALLED IN NORMAL-WEIGHT CONCRETE<sup>1,2,4,5,6</sup> (pounds)**

ANCHOR DIAMETER, <i>d</i> (inch)	HOLE DIAMETER, <i>h<sub>v</sub></i> (inch)	EMBED- MENT DEPTH, <i>h<sub>v</sub></i>	$f'_c = 2,000$ psi			$f'_c = 4,000$ psi			$f'_c = 6,000$ psi		
			Tension		Shear	Tension		Shear	Tension		Shear
			With Sp. Insp. <sup>3</sup>	Without Sp. Insp.		With Sp. Insp. <sup>3</sup>	Without Sp. Insp.		With Sp. Insp. <sup>3</sup>	Without Sp. Insp.	
1/4	3/8	1	285	140	530	495	250	530	520	260	530
3/8	1/2	1 1/2	545	270	1,145	1,045	520	1,145	1,235	620	1,145
1/2	5/8	2	1,025	515	1,600	1,440	720	1,600	1,645	825	1,600
5/8	7/8	2 1/2	1,165	585	3,095	1,860	930	3,095	2,730	1,365	3,095
3/4	1	3	2,145	1,070	3,920	3,600	1,800	3,920	4,325	2,160	3,920

For **SI**: 1 inch = 25.4 mm, 1 psi = 6.89 kPa, 1 lbf = 4.45 N.

<sup>1</sup>The tabulated shear and tension values are for anchors installed in normal-weight concrete that has reached the minimum designated ultimate compressive strength at the time of installation. Linear interpolation may be used for concrete strengths between those listed.

<sup>2</sup>The tabulated values are for anchors installed with spacing and edge distance in accordance with Table 10.

<sup>3</sup>These tension values are applicable only when the anchors are installed with special inspection as set forth in Section 4.3.

<sup>4</sup>Refer to Section 4.1 for design requirements concerning anchors resisting earthquake and wind loads.

<sup>5</sup>The allowable loads for anchors installed with special inspection are calculated using an applied safety factor of 4.0.

<sup>6</sup>Concrete slab thickness must be at least  $1\frac{1}{2}h_v$ .

**TABLE 9—STEEL DROPIN ANCHOR ALLOWABLE TENSION AND SHEAR LOAD VALUES  
WHEN INSTALLED IN STRUCTURAL LIGHTWEIGHT CONCRETE<sup>1,5,6</sup> (pounds)**

ANCHOR INSTALLED IN LIGHTWEIGHT CONCRETE <sup>3,7</sup>									
Anchor Diameter, <i>d</i> (inch)	Drill Bit Diameter (inch)	Embedment Depth, <i>h<sub>v</sub></i> (inches)	Tension						Shear <i>f'<sub>c</sub></i> ≥ 3,000 psi
			With Special Inspection <sup>2</sup>			Without Special Inspection			
			Concrete Strength, <i>f'<sub>c</sub></i>			Concrete Strength, <i>f'<sub>c</sub></i>			
			3,000 psi	4,000 psi	5,000 psi	3,000 psi	4,000 psi	5,000 psi	
1/4	3/8	1	265	340	415	130	170	210	480
3/8	1/2	1 1/2	760	945	1,130	380	470	565	1,030
1/2	5/8	2	1,060	1,210	1,365	530	605	680	1,420
5/8	7/8	2 1/2	1,715	1,960	2,210	860	980	1,105	2,410
3/4	1	3	2,570	2,925	3,280	1,285	1,460	1,640	4,115
ANCHOR INSTALLED THROUGH MIN. 20 GAGE METAL DECK INTO LIGHTWEIGHT CONCRETE ( <i>f'<sub>c</sub></i> ≥ 3,000 psi) <sup>4,8</sup>									
Anchor Diameter, <i>d</i> (inch)	Drill Bit Diameter (inch)	Embedment Depth, <i>h<sub>v</sub></i> (inches)	Minimum 4 1/2" Wide Deck			Minimum 1 1/2" Wide Deck			
			Tension		Shear	Tension		Shear	
			With Sp. Insp. <sup>2</sup>	Without Sp. Insp.		With Sp. Insp. <sup>2</sup>	Without Sp. Insp.		
1/4	3/8	1	240	120	510	150	75	510	
3/8	1/2	1 1/2	240	120	510	150	75	510	
1/2	5/8	2	685	340	1,390	455	225	695	

For SI: 1 inch = 25.4 mm, 1 psi = 6.89 kPa, 1 lbf = 4.48 N.

<sup>1</sup>Tabulated load values are for anchors installed in sand-lightweight concrete that has reached the minimum designated ultimate compressive strength at the time of installation. Linear interpolation may be used for concrete strengths between those listed.

<sup>2</sup>These tension load values are applicable only when the anchors are installed with special inspection as set forth in Section 4.3.

<sup>3</sup>The tabulated load values are for anchors installed with spacing and edge distance in accordance with Table 10.

<sup>4</sup>The tabulated load values are for anchors installed in the center of the flute with spacing distance in accordance with Table 10. Linear interpolation may be used for flute edge distances between those listed. Flute edge distance equals one-half the minimum deck width.

<sup>5</sup>Refer to Section 4.1 for design requirements concerning anchors resisting earthquake and wind loads.

<sup>6</sup>The allowable loads for anchors installed with special inspection are calculated using an applied safety factor of 4.0.

<sup>7</sup>Concrete slab thickness must be at least 1 1/2 *h<sub>v</sub>*.

<sup>8</sup>Anchors are permitted to be installed in the lower or upper flute of the metal deck provided the installation procedures are maintained. See Figure 1.

**TABLE 10—STEEL DROPIN ANCHOR REDUCTION FACTORS FOR SPACING AND EDGE DISTANCE  
IN NORMAL-WEIGHT AND STRUCTURAL LIGHTWEIGHT CONCRETE<sup>1,2</sup>**

ANCHOR INSTALLED IN NORMAL-WEIGHT CONCRETE					
Anchor Dimension	Load Type	Critical Distance (Full Anchor Capacity)	Critical Load Factor	Minimum Distance (Reduced Capacity)	Minimum Load Factor
Spacing (s)	Tension and shear	$s_{cr} = 4.0h_v$	$F_N = F_V = 1.0$	$s_{min} = 2.0h_v$	$F_N = F_V = 0.50$
Edge distance (c)	Tension	$c_{cr} = 14d$	$F_N = 1.0$	$c_{min} = 7d$	$F_N = 0.90$
	Shear	$c_{cr} = 14d$	$F_V = 1.0$	$c_{min} = 7d$	$F_V = 0.50$
ANCHOR INSTALLED IN LIGHTWEIGHT CONCRETE					
Anchor Dimension	Load Type	Critical Distance (Full Anchor Capacity)	Critical Load Factor	Minimum Distance (Reduced Capacity)	Minimum Load Factor
Spacing (s)	Tension and shear	$s_{cr} = 4.0h_v$	$F_N = F_V = 1.0$	$s_{min} = 2.0h_v$	$F_N = F_V = 0.50$
Edge distance (c)	Tension	$c_{cr} = 14d$	$F_N = 1.0$	$c_{min} = 7d$	$F_N = 0.80$
	Shear	$c_{cr} = 14d$	$F_V = 1.0$	$c_{min} = 7d$	$F_V = 0.50$

<sup>1</sup>Load values in the tables are multiplied by the reduction factors when spacing and edge distances are less than critical distances. Linear interpolation is allowed for spacing and edge distances that fall between critical and minimum distances. When a group of anchors is affected by both reduced spacing and reduced edge distance, the spacing and edge distance reduction factors must be combined (multiplied).

<sup>2</sup>All notations used in this table are defined in Table 4.

**TABLE 11—HOLLOW-SET DROPIN ANCHOR ALLOWABLE TENSION AND SHEAR LOAD VALUES  
INSTALLED IN NORMAL-WEIGHT CONCRETE<sup>1,2,4,5,6</sup> (pounds)**

ANCHOR DIAMETER <i>d</i> (inch)	HOLE DIAMETER <i>h<sub>v</sub></i> (inch)	EMBED- MENT DEPTH (inches)	<i>f'<sub>c</sub></i> = 2,000 psi			<i>f'<sub>c</sub></i> = 4,000 psi			<i>f'<sub>c</sub></i> = 6,000 psi		
			Tension		Shear	Tension		Shear	Tension		Shear
			With Sp. Insp. <sup>3</sup>	Without Sp. Insp.		With Sp. Insp. <sup>3</sup>	Without Sp. Insp.		With Sp. Insp. <sup>3</sup>	Without Sp. Insp.	
1/4	3/8	7/8	190	95	360	245	120	360	455	225	360
5/16	5/8	1 1/2	425	215	685	535	265	685	1,135	570	685
3/8	5/8	1 1/2	470	235	785	675	340	785	1,270	635	785
1/2	3/4	2	535	270	1,005	845	420	1,005	2,300	1,150	1,005
5/8	1	2 1/4	1,425	710	1,600	2,290	1,145	1,600	3,020	1,510	1,600

For **SI**: 1 inch = 25.4 mm, 1 psi = 6.89 kPa, 1 lbf = 4.45 N.

<sup>1</sup>The tabulated shear and tension values are for anchors installed in normal-weight concrete that has reached the minimum designated ultimate compressive strength at the time of installation. Linear interpolation may be used for concrete strengths between those listed.

<sup>2</sup>The tabulated values are for anchors installed with spacing and edge distance in accordance with Table 12.

<sup>3</sup>These tension values are applicable only when the anchors are installed with special inspection as set forth in Section 4.3.

<sup>4</sup>Refer to Section 4.1 for design requirements concerning anchors resisting earthquake and wind loads.

<sup>5</sup>The allowable loads for anchors installed with special inspection are calculated using an applied safety factor of 4.0.

<sup>6</sup>Concrete slab thickness must be at least  $1\frac{1}{2}h_v$ .

**TABLE 12—HOLLOW-SET DROPIN ANCHOR REDUCTION FACTORS  
FOR SPACING AND EDGE DISTANCE IN NORMAL-WEIGHT CONCRETE<sup>1,2</sup>**

ANCHOR DIMENSION	LOAD TYPE	CRITICAL DISTANCE (FULL ANCHOR CAPACITY)	CRITICAL LOAD FACTOR	MINIMUM DISTANCE (REDUCED CAPACITY)	MINIMUM LOAD FACTOR
Spacing ( <i>s</i> )	Tension and shear	$s_{cr} = 4.0h_v$	$F_N = F_v = 1.0$	$s_{min} = 2.0h_v$	$F_N = F_v = 0.50$
Edge distance ( <i>c</i> )	Tension	$c_{cr} = 14d$	$F_N = 1.0$	$c_{min} = 8d$	$F_N = 0.80$
	Shear	$c_{cr} = 14d$	$F_v = 1.0$	$c_{min} = 8d$	$F_v = 0.50$

<sup>1</sup>Load values in the tables are multiplied by the reduction factors when spacing and edge distances are less than critical distances. Linear interpolation is allowed for spacing and edge distances that fall between critical and minimum distances. When a group of anchors is affected by both reduced spacing and edge distance, the spacing and edge distance reduction factors must be combined (multiplied).

<sup>2</sup>All notations used in this table are defined in Table 4.

**TABLE 13—SPIKE ANCHOR ALLOWABLE TENSION AND SHEAR LOAD VALUES  
WHEN INSTALLED IN NORMAL-WEIGHT CONCRETE<sup>1,3,4,5,6</sup> (pounds)**

ANCHOR DIAMETER, <i>d</i> (inch)	DRILL BIT DIAMETER (inch)	EMBEDMENT DEPTH, <i>h<sub>v</sub></i> (inches)	TENSION						SHEAR
			With Special Inspection <sup>2</sup>			Without Special Inspection			
			Concrete Strength, <i>f'<sub>c</sub></i>			Concrete Strength, <i>f'<sub>c</sub></i>			<i>f'<sub>c</sub></i> ≥ 3,000 psi
			3,000 psi	4,000 psi	5,000 psi	3,000 psi	4,000 psi	5,000 psi	
3/16	3/16	1 1/4	250	315	380	125	155	190	500
1/4 Pipe Spike	3/16	1 1/4	315	315	315	160	160	160	500
1/4	1/4	1 1/4	300	350	405	150	175	205	505
3/8 Pipe Spike	1/4	1 3/4	415	500	580	205	250	290	505
3/8	3/8	1 3/4	390	445	505	195	225	250	1,120
1/2	1/2	2 1/2	795	885	975	395	440	485	2,115

For **SI**: 1 inch = 25.4 mm, 1 psi = 6.89 kPa, 1 lbf = 4.48 N.

<sup>1</sup>Tabulated load values are for carbon steel anchors installed in normal-weight concrete that has reached the minimum designated ultimate compressive strength at the time of installation. Linear interpolation may be used for concrete strengths between those listed.

<sup>2</sup>These tension load values are applicable only when the anchors are installed with special inspection as set forth in Section 4.3.

<sup>3</sup>The tabulated load values are for anchors installed with spacing and edge distance in accordance with Table 15. The effective anchor diameter, *d*, for the Pipe Spike anchor corresponds to the size of the drill bit diameter.

<sup>4</sup>Refer to Section 4.1 for design requirements concerning anchors resisting earthquake and wind loads.

<sup>5</sup>The allowable loads for anchors installed with special inspection are calculated using a minimum applied safety factor of 4.0.

<sup>6</sup>Concrete slab thickness must be at least  $1\frac{1}{2}h_v$ .

**TABLE 14—SPIKE ANCHOR ALLOWABLE TENSION AND SHEAR LOAD VALUES  
WHEN INSTALLED IN STRUCTURAL LIGHTWEIGHT CONCRETE<sup>1,5,6</sup> (pounds)**

ANCHOR INSTALLED IN LIGHTWEIGHT CONCRETE <sup>3,7</sup>									
Anchor Diameter, <i>d</i> (inch)	Drill Bit Diameter (inch)	Embedment Depth, <i>h<sub>v</sub></i> (inches)	Tension						SHEAR
			With Special Inspection <sup>2</sup>			Without Special Inspection			
			Concrete Strength, <i>f'<sub>c</sub></i>			Concrete Strength, <i>f'<sub>c</sub></i>			<i>f'<sub>c</sub></i> ≥ 3,000 psi
			3,000 psi	4,000 psi	5,000 psi	3,000 psi	4,000 psi	5,000 psi	
<sup>3</sup> / <sub>16</sub>	<sup>3</sup> / <sub>16</sub>	1 <sup>1</sup> / <sub>4</sub>	110	100	95	55	50	45	320
<sup>1</sup> / <sub>4</sub>	<sup>1</sup> / <sub>4</sub>	1 <sup>1</sup> / <sub>4</sub>	120	110	100	60	55	50	430
<sup>3</sup> / <sub>8</sub>	<sup>3</sup> / <sub>8</sub>	1 <sup>3</sup> / <sub>4</sub>	285	240	200	140	120	100	750
<sup>1</sup> / <sub>2</sub>	<sup>1</sup> / <sub>2</sub>	2 <sup>1</sup> / <sub>2</sub>	465	465	465	230	230	230	1,610
ANCHOR INSTALLED THROUGH MIN. 20 GAGE METAL DECK INTO LIGHTWEIGHT CONCRETE ( <i>f'<sub>c</sub></i> ≥ 3,000 psi) <sup>4,8</sup>									
Anchor Diameter, <i>d</i> (inch)	Drill Bit Diameter (inch)	Embedment Depth, <i>h<sub>v</sub></i> (inches)	Minimum 1 <sup>1</sup> / <sub>2</sub> " Wide Deck						Shear
			Tension						
			With Special Inspection <sup>2</sup>			Without Special Inspection <sup>2</sup>			
<sup>3</sup> / <sub>16</sub>	<sup>3</sup> / <sub>16</sub>	1 <sup>1</sup> / <sub>4</sub>	140			70			500
<sup>1</sup> / <sub>4</sub>	<sup>1</sup> / <sub>4</sub>	1 <sup>1</sup> / <sub>4</sub>	140			70			500
<sup>3</sup> / <sub>8</sub>	<sup>3</sup> / <sub>8</sub>	1 <sup>3</sup> / <sub>4</sub>	150			75			655
<sup>1</sup> / <sub>2</sub>	<sup>1</sup> / <sub>2</sub>	2 <sup>1</sup> / <sub>2</sub>	280			140			755

For **SI**: 1 inch = 25.4 mm, 1 psi = 6.89 kPa, 1 lbf = 4.48 N.

<sup>1</sup>Tabulated load values are for anchors installed in sand-lightweight concrete that has reached the minimum designated ultimate compressive strength at the time of installation. Linear interpolation may be used for concrete strengths between those listed.

<sup>2</sup>These tension load values are applicable only when the anchors are installed with special inspection as set forth in Section 4.3.

<sup>3</sup>The tabulated load values are for anchors installed with spacing and edge distance in accordance with Table 15.

<sup>4</sup>The tabulated load values are for anchors installed in the center of the flute with spacing distance in accordance with Table 15. Flute edge distance equals one-half the minimum deck width.

<sup>5</sup>Refer to Section 4.1 for design requirements concerning anchors resisting earthquake and wind loads.

<sup>6</sup>The allowable loads for anchors installed with special inspection are calculated using an applied safety factor of 4.0.

<sup>7</sup>Concrete slab thickness must be at least 1<sup>1</sup>/<sub>2</sub>*h<sub>v</sub>*.

<sup>8</sup>Anchors are permitted to be installed in the lower or upper flute of the metal deck provided the installation procedures are maintained. See Figure 1.

**TABLE 15—SPIKE ANCHOR REDUCTION FACTORS FOR SPACING AND EDGE DISTANCE  
IN NORMAL-WEIGHT AND STRUCTURAL LIGHTWEIGHT CONCRETE<sup>1,2</sup>**

ANCHOR INSTALLED IN NORMAL-WEIGHT CONCRETE					
Anchor Dimension	Load Type	Critical Distance (Full Anchor Capacity)	Critical Load Factor	Minimum Distance (Reduced Capacity)	Minimum Load Factor
Spacing (s)	Tension and shear	$s_{cr} = 4.0h_v$	$F_N = F_v = 1.0$	$s_{min} = 2.0h_v$	$F_N = F_v = 0.50$
Edge distance (c)	Tension	$c_{cr} = 14d$	$F_N = 1.0$	$c_{min} = 5d$	$F_N = 0.50$
	Shear	$c_{cr} = 14d$	$F_v = 1.0$	$c_{min} = 5d$	$F_v = 0.25$
ANCHOR INSTALLED IN LIGHTWEIGHT CONCRETE					
Anchor Dimension	Load Type	Critical Distance (Full Anchor Capacity)	Critical Load Factor	Minimum Distance (Reduced Capacity)	Minimum Load Factor
Spacing (s)	Tension and shear	$s_{cr} = 4.0h_v$	$F_N = F_v = 1.0$	$s_{min} = 2.0h_v$	$F_N = F_v = 0.50$
Edge distance (c)	Tension	$c_{cr} = 14d$	$F_N = 1.0$	$c_{min} = 7d$	$F_N = 1.0$
	Shear	$c_{cr} = 14d$	$F_v = 1.0$	$c_{min} = 7d$	$F_v = 0.40$

<sup>1</sup>Load values in the tables are multiplied by the reduction factors when spacing and edge distances are less than critical distances. Linear interpolation is allowed for spacing and edge distances that fall between critical and minimum distances. When a group of anchors is affected by both reduced spacing and reduced edge distance, the spacing and edge distance reduction factors must be combined (multiplied).

<sup>2</sup>All notations used in this table are defined in Table 4.

TABLE 16—LENGTH IDENTIFICATION SYSTEM

CODE ON ANCHOR		A	B	C	D	E	F	G	H	I	J	K	L	M
Length of anchor (inches)	From	1 1/2	2	2 1/2	3	3 1/2	4	4 1/2	5	5 1/2	6	6 1/2	7	7 1/2
	Up to but not including	2	2 1/2	3	3 1/2	4	4 1/2	5	5 1/2	6	6 1/2	7	7 1/2	8

CODE ON ANCHOR		N	O	P	Q	R	S	T	U	V	W	X	Y	Z
Length of anchor (inches)	From	8	8 1/2	9	9 1/2	10	11	12	13	14	15	16	17	18
	Up to but not including	8 1/2	9	9 1/2	10	11	12	13	14	15	16	17	18	19

For SI: 1 inch = 25.4 mm.

TABLE 17—CROSS REFERENCE OF PRODUCT NAMES

POWERS FASTENERS, INC.	L.H. DOTTIE COMPANY	GRABBER
Power-Stud Anchor	Dottie Wedge Anchor	Grabber Wedge Anchor
Steel Dropin Anchor	Dottie Drop-in Anchor	Grabber Drop-in Anchor

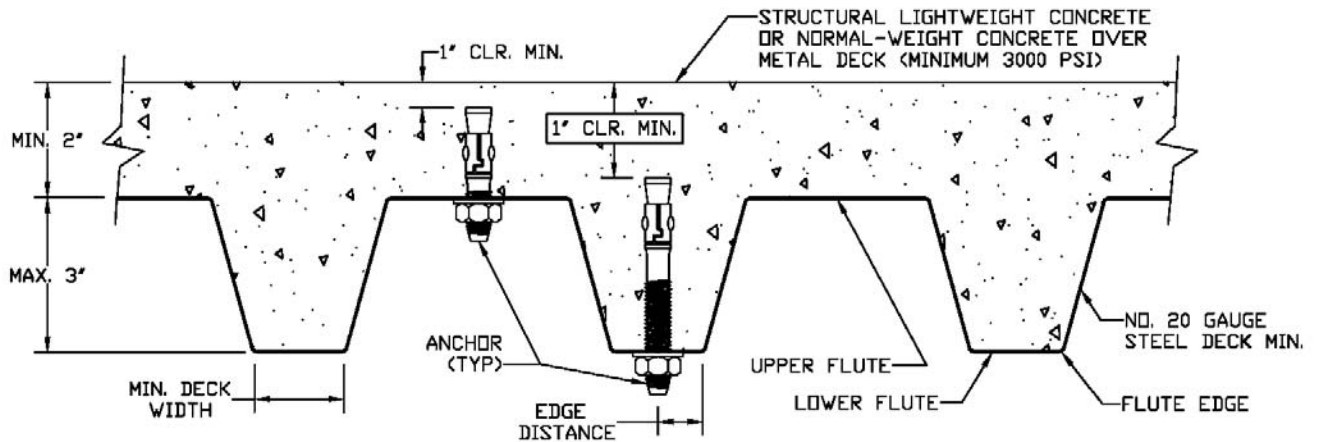

FIGURE 1—POWERS ANCHOR INSTALLATION IN STEEL DECK WITH CONCRETE FILL